

# Technical data sheet

## Wall and support bracket MWAM 12

Item no. 6424552



Light-duty wall and support bracket including quick connector for use with cable trays of type RKSM.



<b>St</b>	Steel
<b>FS</b>	Strip galvanised

Additional product text, instruction	Wall and support bracket MWAM.. including: 1. Two pre-mounted quick connectors for efficient cable tray fastening. 2. Truss-head bolt M10 x 25 for fastening on the U support.
Product text, scope of delivery	Including truss-head screw M10 x 25 for fastening to U supports.

### Master data

Item no.	6424552
Type	MWAM 12 21 FS
Description 1	Wall and support bracket
Description 2	including quick fastening
Dimension	B210mm
Material	Steel
Material symbol	St
Surface	Strip galvanised
Surface to DIN	DIN EN 10346
Surface symbol	FS
Smallest sales unit (VG)	1,00 Piece
Weight	26,00 kg/100 pc.

# Technical data sheet

## Wall and support bracket MWAM 12

Item no. 6424552



### Technical data

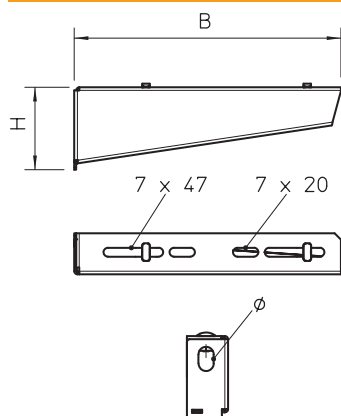

Length	32,50 mm
Width	210,00 mm
Side height	65,00 mm
Dimension A	32,50 mm
Dimension B	210,00 mm
Dimension H	65,00 mm
Hole diameter	11,00 mm
Version	Wall and support brackets
Version	Wall and support bracket
F in kN	1,20 kN
Suitable for maintaining electrical function	<input type="checkbox"/>
Rustproof steel, pickled	<input type="checkbox"/>
Angle range	90,00 - 90,00 °

# Technical data sheet

## Wall and support bracket MWAM 12

Item no. 6424552



### Load charts

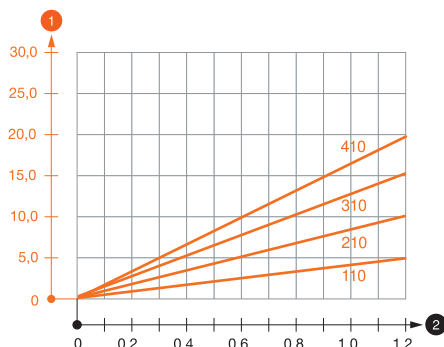

Load values heading\_Characteristic anchor values  
Load values heading\_Bracket\_Support  
Heading, load table  
Footnote, load table

Characteristic anchor load values for wall and support bracket MWAM 12

Load values for MWAM 12 on support

Wall bracket load

Max. total load  $F$  = cable weight + cable tray + bracket. The load capacity values increase considerably when used in uncracked concrete. The values given are based on concrete of strength class C20/25. Observe the installation conditions of the DIBt approval (anchors).

Load diagram, bracket type MWAM 12

- 1 Bending of the bracket tip at permitted bracket load
- 2 Permitted bracket load in kN without man load
- Load curve with bracket lengths in mm

### Characteristic anchor load values for wall and support bracket MWAM 12

Wall fastening		Max. load $F$ [kN]			
		Bracket width [mm]			
		110	210	310	410
Anchor type					
BZ-U 8-10-21/75	1,20	0,95	0,70	0,65	
BZ-U 10-10-30/90	1,20	1,20	1,20	1,20	

Max. total load  $F$  = cable weight + cable tray + bracket. The load capacity values increase considerably when used in uncracked concrete. The values given are based on concrete of strength class C20/25. Observe the installation conditions of the DIBt approval (anchors).

### Load values for MWAM 12 on support

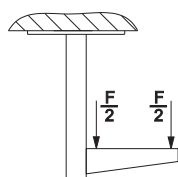

### Load values for MWAM 12 on support

#### Characteristic anchor load values for wall and support bracket MWAM 12

T1	Wall fastening				
T2		Max. load $F$ [kN]			
T3		Bracket width [mm]			
T4	Anchor type	110	210	310	410
	BZ-U 8-10-21/75	1,2	0,95	0,7	0,65
	BZ-U 10-10-30/90	1,2	1,2	1,2	1,2