

Technical data sheet

Wall and support bracket AWG 15

Item no. 6420608



Light-duty wall and support bracket with welded head plate for screwless mesh cable tray fastening.



St	Steel
FT	Hot-dip galvanised

Additional product text, instruction: Fastening of the bracket to the U support of width 400 mm or greater using a hexagonal bolt through both sides of the support. Please insert suitable spacers.

Master data

Item no.	6420608
Type	AW G 15 21 FT
Description 1	Wall and support bracket
Description 2	for mesh cable tray
Dimension	B210mm
Material	Steel
Material symbol	St
Surface	Hot-dip galvanised
Surface to DIN	DIN EN ISO 1461
Surface symbol	FT
Smallest sales unit (VG)	1,00 Piece
Weight	26,00 kg/100 pc.

Technical data

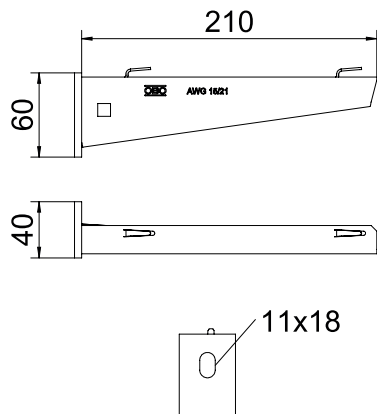

Width	210,00 mm
Side height	60,00 mm
Dimension A	40,00 mm
Dimension B	210,00 mm
Dimension H	60,00 mm
Dimension L	210,00 mm
Hole diameter	11,00 mm
Dimension value	210 x 60
Version	Wall and support brackets
Version	Wall and support bracket
F in kN	1,50 kN
for width	200,00 - 200,00 mm
Suitable for maintaining electrical function	<input type="checkbox"/>
Rustproof steel, pickled	<input type="checkbox"/>

Technical data sheet

Wall and support bracket AWG 15

Item no. 6420608



Technical data

Angle range	90,00 - 90,00 °
-------------	-----------------

Technical data sheet

Wall and support bracket AWG 15

Item no. 6420608



Load charts

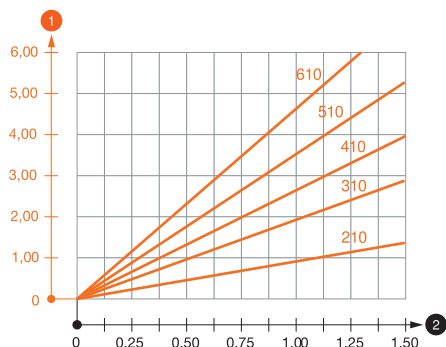

Load values heading_Characteristic anchor values
Load values heading_Bracket_Support
Heading, load table
Footnote, load table

Characteristic anchor load values for wall and support bracket AWG 15

Load values for AWG 15 on support

Wall bracket load

Max. total load F = cable weight + cable tray + bracket. The load capacity values increase considerably when used in uncracked concrete. The values given are based on concrete of strength class C20/25. Observe the installation conditions of the DIBt approval (anchors).

Load diagram, bracket type AWG 15

- 1 Bending of the bracket tip at permitted bracket load
- 2 Permitted bracket load in kN without man load
- Load curve with bracket lengths in mm

Characteristic anchor load values for wall and support bracket AWG 15

Wall fastening		Max. load F [kN]							
		Bracket width [mm]							
Anchor type		110	160	210	310	410	510	560	610
	BZ-U 8-10-21/75	1,10	0,90	0,80	0,65	0,55	0,50	0,45	0,45
	BZ-U 10-10-30/90	1,50	1,50	1,40	1,10	0,95	0,85	0,80	0,80

Max. total load F = cable weight + cable tray + bracket. The load capacity values increase considerably when used in uncracked concrete. The values given are based on concrete of strength class C20/25. Observe the installation conditions of the DIBt approval (anchors).

Load values for AWG 15 on support

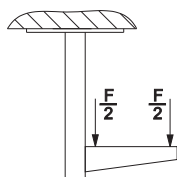

Load values for AWG 15 on support

Characteristic anchor load values for wall and support bracket AWG 15

T1	Wall fastening								
T2		Max. load F [kN]							
T3		Bracket width [mm]							
T4	Anchor type	110	160	210	310	410	510	560	610
	BZ-U 8-10-21/75	1,1	0,9	0,8	0,65	0,55	0,5	0,45	0,45
	BZ-U 10-10-30/90	1,5	1,5	1,4	1,1	0,95	0,85	0,8	0,8