

Technical data sheet

Wall and support bracket AW 30

Item no. 6419836

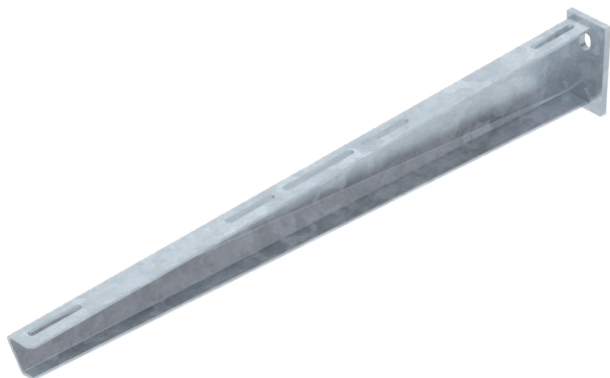

Medium-duty wall and support bracket with welded head plate.



St	Steel
FT	Hot-dip galvanised

Additional product text, instruction: Fastening of the bracket to the U support of width 400 mm or greater using a hexagonal bolt through both sides of the support. Please insert suitable spacers.

Master data

Item no.	6419836
Type	AW 30 71 FT
Description 1	Wall and support bracket
Description 2	with welded head plate
Dimension	B710mm
Material	Steel
Material symbol	St
Surface	Hot-dip galvanised
Surface to DIN	DIN EN ISO 1461
Surface symbol	FT
Smallest sales unit (VG)	1,00 Piece
Weight	207,00 kg/100 pc.

Technical data

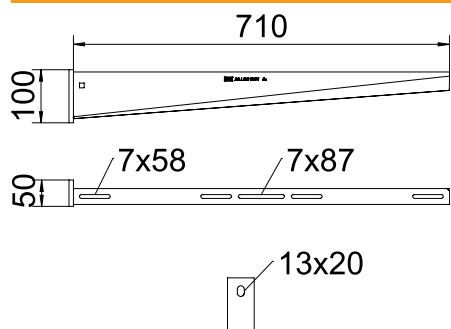

Width	710,00 mm
Dimension A	50,00 mm
Dimension B	710,00 mm
Dimension H	100,00 mm
Dimension L	710,00 mm
Hole diameter	13,00 mm
Dimension value	710 x 100
Version	Wall and support brackets
Version	Wall and support bracket
F in kN	3,00 kN
Suitable for maintaining electrical function	<input type="checkbox"/>
Rustproof steel, pickled	<input type="checkbox"/>
Angle range	90,00 - 90,00 °

Technical data sheet

Wall and support bracket AW 30

Item no. 6419836



Load charts

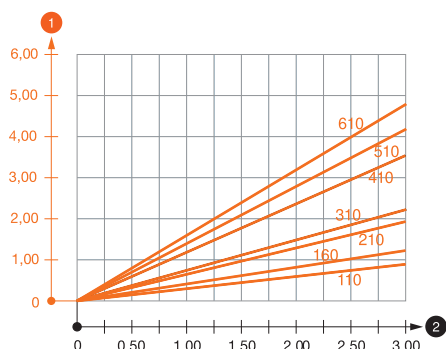

Load values heading_Characteristic anchor values
Load values heading_Bracket_Support
Heading, load table
Footnote, load table

Characteristic anchor load values for wall and support bracket AW 30

Load values for AW 30 on suspended support

Wall bracket load

Max. total load $F = \text{cable weight} + \text{cable tray} + \text{bracket}$. The load capacity values increase considerably when used in uncracked concrete. The values given are based on concrete of strength class C20/25. Observe the installation conditions of the DIBt approval (anchors).

Load diagram, bracket, type AW 30

1 Bending of the bracket tip at permitted bracket load

2 Permitted bracket load in kN without man load

— Load curve with bracket lengths in mm

Characteristic anchor load values for wall and support bracket AW 30

Wall fastening

Anchor type	Max. load F [kN]						
	Bracket width [mm]						
	110	160	210	310	410	510	560
BZ-U 10-10-30/90	1,50	2,10	1,65	1,40	1,50	1,00	1,00
BZ 12-15-35/110	3,00	2,65	2,90	1,50	1,90	1,80	1,75
* Values with tray width 600							

Max. total load $F = \text{cable weight} + \text{cable tray} + \text{bracket}$. The load capacity values increase considerably when used in uncracked concrete. The values given are based on concrete of strength class C20/25. Observe the installation conditions of the DIBt approval (anchors).

Load values for AW 30 on suspended support

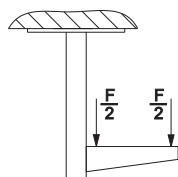

Load values for AW 30 on suspended support

Characteristic anchor load values for wall and support bracket AW 30

T1	Wall fastening							
T2		Max. load F [kN]						
T3		Bracket width [mm]						
T4	Anchor type	110	160	210	310	410	510	560
	BZ-U 10-10-30/90	1,5	2,1	1,65	1,4	1,5	1	1
	BZ 12-15-35/110	3,00	2,65	2,9	1,5	1,9	1,8	1,75
Tsub		* Values with tray width 600						