

Technical data sheet

Wall and support bracket AW 30

Item no. 6442854



Medium-duty wall and support bracket with welded head plate.



A2	Stainless steel, rustproof 1.4301
2B	Bright, reworked

Additional product text, instruction: Fastening of the bracket to the U support of width 400 mm or greater using a hexagonal bolt through both sides of the support. Please insert suitable spacers.

Master data

Item no.	6442854
Type	AW 30 31 A2
Description 1	Wall and support bracket
Description 2	with welded head plate
Dimension	B310mm
Material	Stainless steel, material no. 1.4301
Material symbol	A2
Surface	Bright, reworked
Surface symbol	2B
Smallest sales unit (VG)	1,00 Piece
Weight	60,50 kg/100 pc.

Technical data

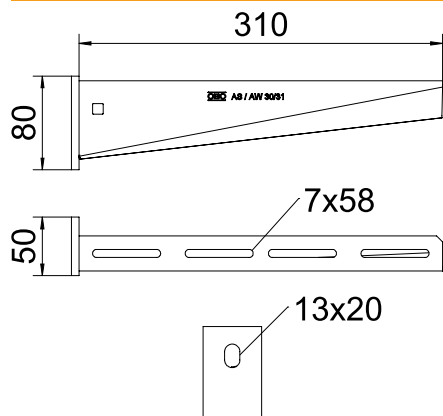

Length	310,00 mm
Width	310,00 mm
Side height	80,00 mm
Dimension A	50,00 mm
Dimension B	310,00 mm
Dimension H	80,00 mm
Dimension L	310,00 mm
Hole diameter	13,00 mm
Dimension value	310 x 80
Version	Wall and support brackets
Version	Wall and support bracket
F in kN	3,00 kN
Suitable for maintaining electrical function	<input type="checkbox"/>
Rustproof steel, pickled	<input checked="" type="checkbox"/>

Technical data sheet

Wall and support bracket AW 30



Item no. 6442854

Technical data

Angle range | 90,00 - 90,00 °

Load charts

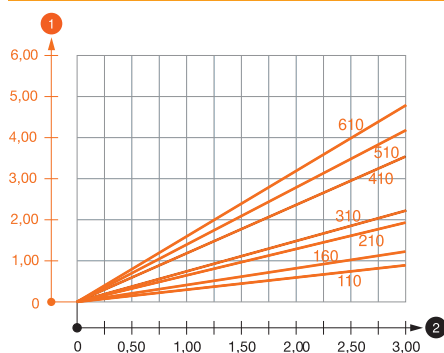

Load values heading_Characteristic anchor values
Heading, load table
Footnote, load table

Characteristic anchor load values for wall and support bracket AW 30

Wall bracket load

Max. total load $F = \text{cable weight} + \text{cable tray} + \text{bracket}$. The load capacity values increase considerably when used in uncracked concrete. The values given are based on concrete of strength class C20/25. Observe the installation conditions of the DIBt approval (anchors).

Load diagram, bracket AW 30 VA

- 1 Bending of the bracket tip at permitted bracket load
- 2 Permitted bracket load in kN without man load
- Load curve with bracket lengths in mm

Characteristic anchor load values for wall and support bracket AW 30

Bracket load		Max. total load F in kN						
	Anchor	Bracket length in mm						
	Permitted							
	F kN	100	200	300	400	500	600	
	3,57	1,66	1,12	0,99	0,76	0,74	0,74	
	4,76	2,21	1,50	1,32	1,01	0,99	0,99	

Max. total load $F = \text{cable weight} + \text{cable tray} + \text{bracket}$. The load capacity values increase considerably when used in uncracked concrete. The values given are based on concrete of strength class C20/25. Observe the installation conditions of the DIBt approval (anchors).

Characteristic anchor load values for wall and support bracket AW 30

T1	Bracket load						
T2	Anchor	Max. total load F in kN					
T3	Permitted	Bracket length in mm					
T4	F kN	100	200	300	400	500	600
	3,57	1,66	1,12	0,99	0,76	0,74	0,74
	4,76	2,21	1,50	1,32	1,01	0,99	0,99