

Technical data sheet

Wall and ceiling clamp

Item no. 6363744

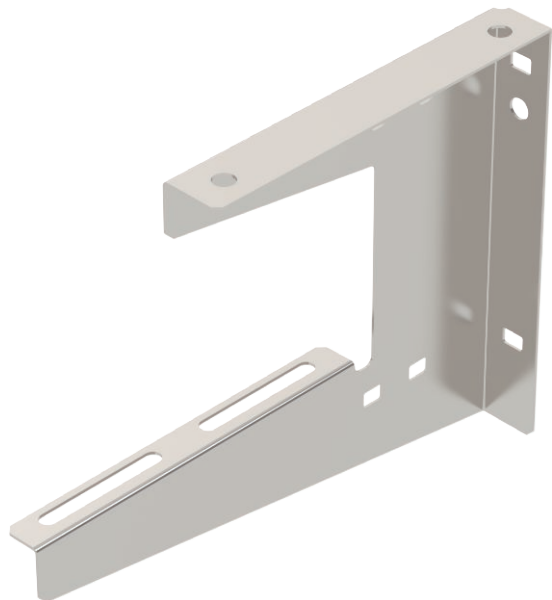

Wall and ceiling clamp for universal structural fastening.



A2 Stainless steel, rustproof 1.4301
2B Bright, reworked

Master data

Item no.	6363744
Type	WDB L 150 A2
Description 1	Wall and ceiling strap
Description 2	lightweight version
Dimension	B150mm
Material	Stainless steel, material no. 1.4301
Material symbol	A2
Surface	Bright, reworked
Surface symbol	2B
Smallest sales unit (VG)	1,00 Piece
Weight	24,00 kg/100 pc.

Technical data sheet

Wall and ceiling clamp

Item no. 6363744



Technical data

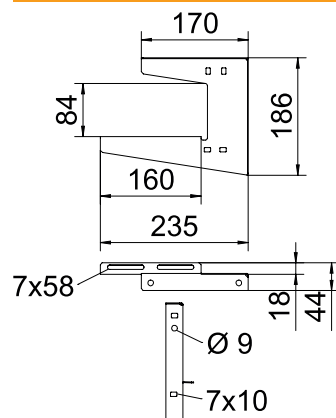

Length	235,00 mm
Width	160,00 mm
Height	186,00 mm
Dimension B	160,00 mm
Dimension H	186,00 mm
Dimension h1	84,00 mm
Dimension L	235,00 mm
Version	Suspension bracket (C clamp)
Tray fastening	Screw-on
F in ceiling	0,22 kN
F in kN wall	0,22 kN
for width	150,00 mm
for threaded rod	M8
For metric threaded rod	8,00
Suitable for tray/ladder width	150,00 mm
Suitable for maintaining electrical function	<input type="checkbox"/>
Suitable for cable tray	<input checked="" type="checkbox"/>
Suitable for cable ladder	<input checked="" type="checkbox"/>
Suitable for mesh cable tray	<input checked="" type="checkbox"/>
Hole diameter	7,00 mm
Material thickness	1,25 mm
Adjustable	<input type="checkbox"/>

Appr. load:

Technical data sheet

Wall and ceiling clamp

Item no. 6363744



Technical data

Appr. load: