



BALL VALVES SENA BOILERS

Ball valves allows quick and easy installation due to its loose nut connection. The handle design makes it ideal for tight spaces or places with difficult access.



- Reinforced compact handle, ideal for tight spaces. Its shape allows manual operation or with a 27 mm fixed wrench.
- Blocking system with solid handle stopper.
- Red and blue index, distinguish between hot and cold water.
- European Brass, DW (4MS) quality for use in drinking water installations.
- Nickel-free water passage for greater healthiness.
- Male or female connections, as well as straight or angle valve configuration.
- Female loose nut with flat fiber joint, ensures tightness and facilitate installation.



TECHNICAL SHEET BALL VALVES SENA BOILERS

PRODUCT DESCRIPTION

Ball valves with manual operation. They have a loose nut connection and compact handle, to facilitate their installation in tight spaces or places with difficult access.

PRODUCT SCOPE

Specially designed for gas boiler installations for heating, DHW or mixed.

And in general, all those applications that require a valve capable of shutting off the supply of a fluid, guaranteeing tightness in accordance with the specified service conditions.

GENERAL DIMENSIONS, PRESSURE AND TEMPERATURE

FEMALE ANGLE – LOOSE NUT

Code	Thread	A* (mm)	B (mm)	C (mm)	PN (bar)	Temp (°C)**
150803	1/2	45	31	74	30	-20 to 120
150804	3/4	45	36	82	30	-20 to 120

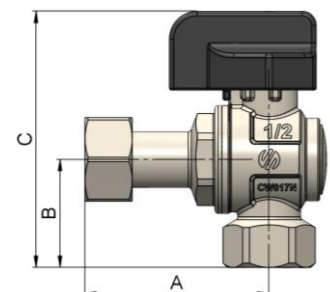

MALE ANGLE – LOOSE NUT

Code	Thread	A* (mm)	B (mm)	C (mm)	PN (bar)	Temp (°C)**
150813	1/2	45	35	78	30	-20 to 120
150814	3/4	45	42	88	30	-20 to 120

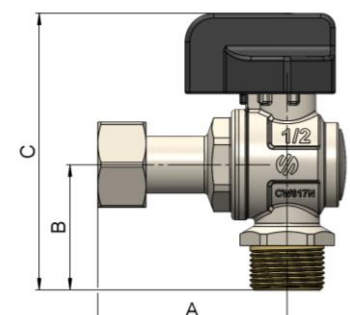

Threading according to ISO228

* From the flat joint surface.

** Freezing is excluded.

MALE ANGLE – LOOSE NUT WITH FILTER

Code	Thread	A* (mm)	B (mm)	C (mm)	PN (bar)	Temp (°C)**
150823	1/2	89	59	52	30	-20 to 120
150824	3/4	93	62	54	30	-20 to 120

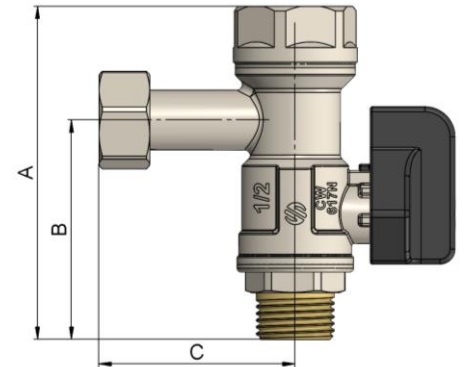
MALE ANGLE – LOOSE NUT WITH FILTER AND CHECK VALVE

Code	Thread	A* (mm)	B (mm)	C (mm)	PN (bar)	Temp (°C)**
150833	1/2	89	59	52	30	-20 to 120
150834	3/4	92	62	54	30	-20 to 120

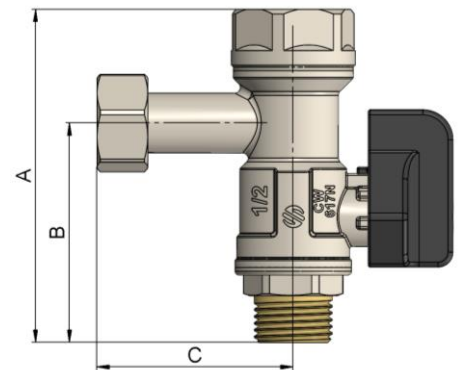
FEMALE STRAIGHT – LOOSE NUT

Code	Thread	A* (mm)	B (mm)	C (mm)	PN (bar)	Temp (°C)**
150853	1/2	78	53	43	30	-20 to 120
150854	3/4	80	50	46	30	-20 to 120

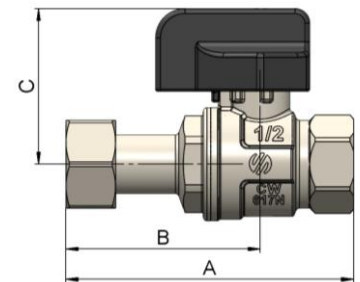
MALE STRAIGHT – LOOSE NUT

Code	Thread	A* (mm)	B (mm)	C (mm)	PN (bar)	Temp (°C)**
150863	1/2	79	51	43	30	-20 to 120
150864	3/4	80	50	46	30	-20 to 120

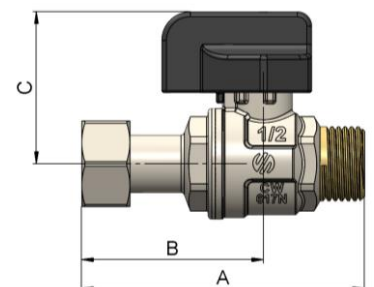

Available in pack format: KVC01, KVC02, KVC03, KVC04, KVC05, KVC06 y KVC07
Consult catalogue / tariff.

Threading according to ISO228

* From the flat joint surface.

** Freezing is excluded.

MATERIALS

Item	Component	Material	Finishing
1	Cap	Brass CW617N	Outer nickel-plated Nickwl-free inner
2	Flat joint	Fiber	-
3	Filter	Stainless steel	Stainless steel
4	Handle	ZAMAK	Black Epoxy
5	Index	ABS	Blue and Red
6	Screw	Stainless steel	Stainless steel
7	Gland nut	Brass CW617N	Nickel plated
8	Stem	Brass CW617N	Brass color
9	Gland	PTFE	-
10	Ball	Brass CW617N	Chrome plated
11	Lateral	Brass CW617N	Outer nickel-plated Nickwl-free inner
12	Seat	PTFE	-
13	Body	Brass CW617N	Outer nickel-plated Nickwl-free inner
14	Ring	Stainless steel	Stainless steel
15	Flat joint	Fiber	-
16	Nut	Brass CW617N	Outer nickel-plated Nickwl-free inner

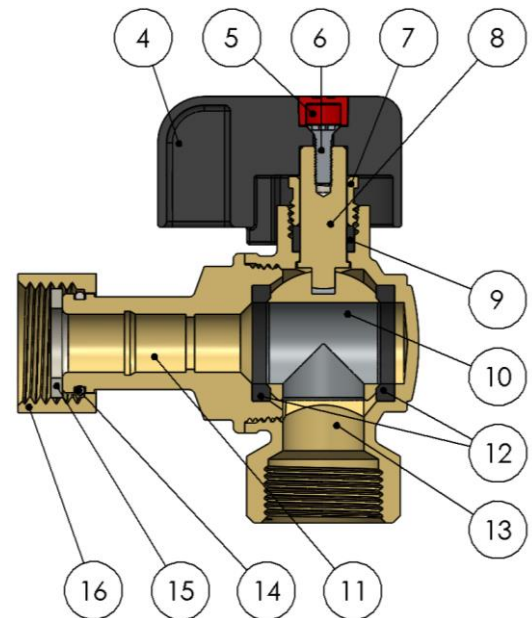
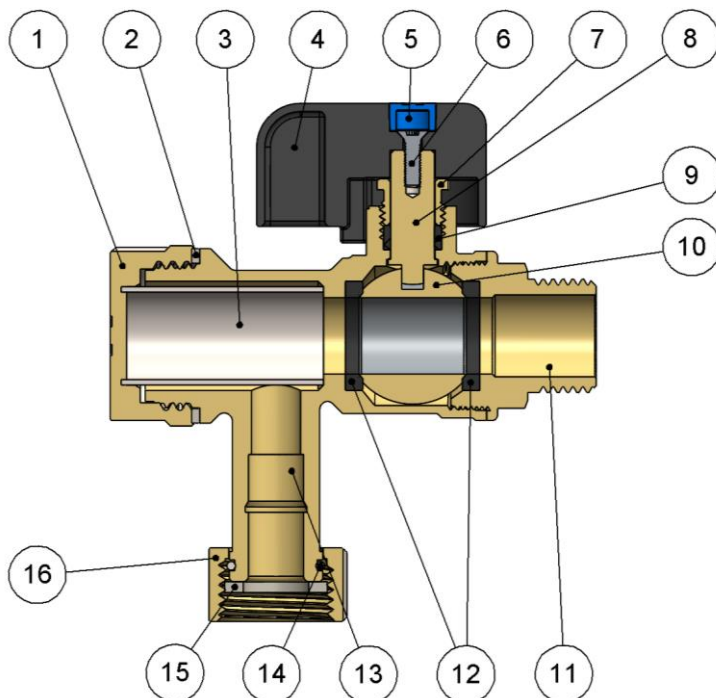

The 150833 and 150834 models incorporate a check valve.



TECHNICAL DATA

Pressure vs. temperature.

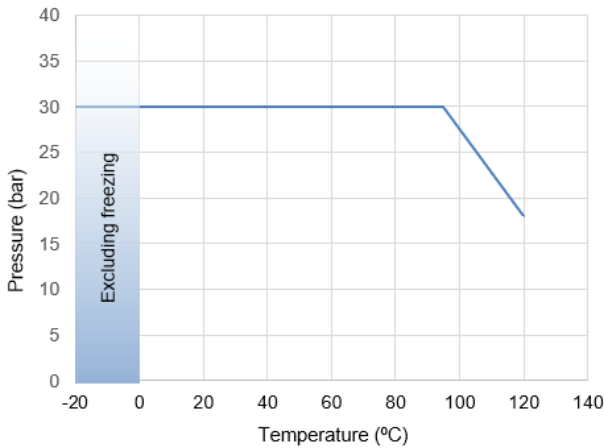

Hydraulic features. Flow vs. loss of pressure.

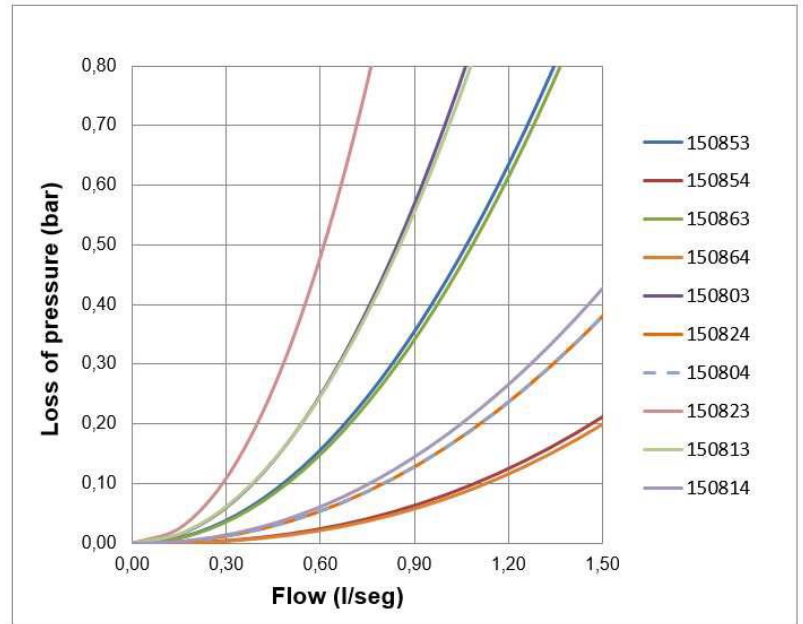

Compatibility with fluids

Fluid	Compatibility
Drinking water and domestic hot water	Excellent
Water + 50% Glycol (maximum)	Good
Air	Medium

For any other fluid, please contact Arco technical service.

	Straight		Angle		Filter	
Size	1/2	3/4	1/2	3/4	1/2	3/4
Kv (male)	5,3	10,6	4,30	8	3	5,5
Kv (female)	5,4	11	4,33	8,6	-	-

Kv (m³/h), cubic meters per hour that flow through the valve generating a loss of 1 bar pressure.

INSTALLATION INSTRUCTIONS

Before performing any action, the water supply to the installation should be shut off. Make sure there is no dirt or foreign objects in the connection to the network. The valve should be installed with a suitable tool, preferably with a fixed wrench that fits into the planes of the hexagons of the valve, avoiding deforming this areas due to excessive pressure from the tool. The assembly of the loose nut connection should be done with the appropriate tool, the torque applied should be controlled to prevent the flat joint from being cut. Never apply force in the central area of the valve as the internal mechanism can be irreparably damaged. Do not alter the assembly of the valve components, it may cause external leakage. Ball valves work completely open or closed, leaving them in intermediate positions can reduce their service life or even damage them. It is recommended to perform opening and closing maneuvers every 3 months, avoiding blockages. In hard or very hard water areas, we recommend reducing this time.



All products have an environmental impact during its life cycle, even once retired. All the components of this product can be recycled. Once the use is over, leave the valve in any recycling green point. Válvulas Arco reserves the right to change the product or any of its technical specifications without prior notice.

FT18030ING – Edition 2024-12