

V-TAC

Meaningful Innovation.

WEEE Number: 80133970

INSTRUCTION MANUAL INFRERED MOTION SENSOR

TECHNICAL DATA

MODEL	VT-80140
SKU	24110
RATED LOAD	[Traditional Lighting] 1200W [LED Lighting] 600W
INPUT VOLTAGE	220-240V/AC
POWER FREQUENCY	50/60Hz
AMBIENT LIGHT	<3-2000 LUX (Adjustable)
TIME DELAY	Min. 10sec±3sec Max. 15min±2min
DETECTION RANGE	180°/360°
DETECTION DISTANCE	12m (<24°C)
WORKING TEMPERATURE	-20~+40°C
WORKING HUMIDITY	<93%RH
INSTALLATION HEIGHT	1.8 - 2.5m
POWER CONSUMPTION	< 0.5W
DETECTION MOTION SPEED	0.6 - 1.5m/s
DIMENSION	80.2x68x55.5mm



05 YEAR
WARRANTY* **IP44**
RATING

COMPATIBLE WITH
V-TAC LED
RANGE [UPTO 600W]

INTRODUCTION & WARRANTY

Thank you for selecting and buying V-TAC product. V-TAC will serve you the best. Please read these instructions carefully before starting the installing and keep this manual handy for future reference. If you have any another query, please contact our dealer or local vendor from whom you have purchased the product. They are trained and ready to serve you at the best. The warranty is valid for 5 years from the date of purchase. The warranty does not apply to damage caused by incorrect installation or abnormal wear and tear. The company gives no warranty against damage to any surface due to incorrect removal and installation of the product. The products are suitable for 10-12 Hours Daily operation. Usage of product for 24 Hours a day would void the warranty. This product is warranted for manufacturing defects only.

WARNING

- Please make sure to turn off the power before starting the installation.
- Installation should only be done by a certified electrician.
- For indoor use only.



FR

Cet appareil,
ses accessoires
et cordons
se recyclent

À DÉPOSER
EN MAGASIN



ou

À DÉPOSER
EN DÉCHÈTERIE



Points de collecte sur www.quefairedemesdechets.fr
Privilégiez la réparation ou le don de votre appareil !

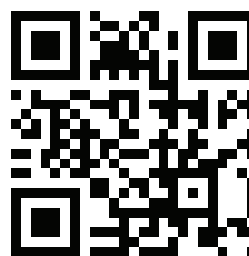

**MULTI-LANGUAGE
MANUAL QR CODE**

Please scan the QR code
to access the manual in
multiple languages.



This marking indicates that this product should not be disposed of with other household wastes.

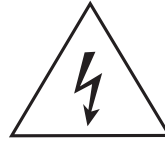

Caution, risk of electric shock.

FUNCTION

- Can identify day and night: The consumer can adjust working state in different ambient light. It can work in the daytime and at night when it is adjusted on the “sun” position (max). It can work in the ambient light less than 3LUX when it is adjusted on the “3” position (min). As for the adjustment pattern, please refer to the testing pattern.
- Time-Delay is added continually: When it receives the second induction signals within the first induction, it will restart to time from the moment.

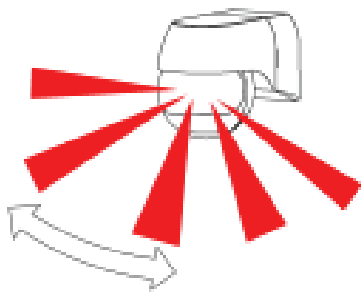

Good sensitivity

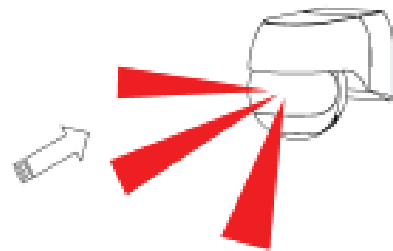
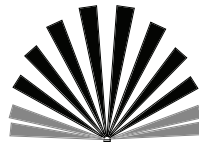

Poor sensitivity

INSTALLATION ADVICE

As the detector responds to changes in temperature, avoid the following situations

- Avoid pointing the detector towards objects with highly reflective surfaces, such as mirrors etc.
- Avoid mounting the detector near heat sources, such as heating vents, air conditioning units, light etc.
- Avoid pointing the detector towards objects that may move in the wind, such as curtains, tall plants etc.

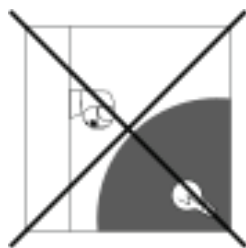
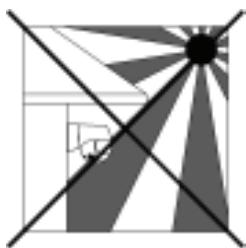

CONNECTION

- Loosen the screw in the back and unload the bottom (refer to figure 1).
- Find the wire hole with gasket in the downside of the sensor and pass the power wire through hole. Connect the power wire into connection-wire column according to the connection-wire diagram.
- Fix the bottom with inflated screw on the selected position. (refer to figure 2)
- Install back the sensor on the bottom, tighten the screw and then test it.

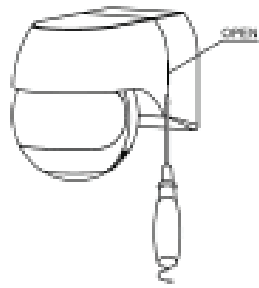

Figure 1

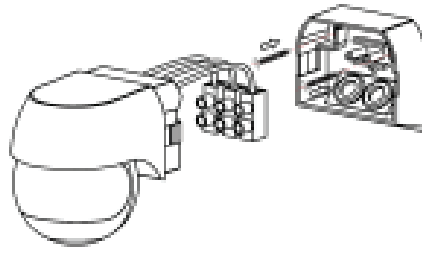
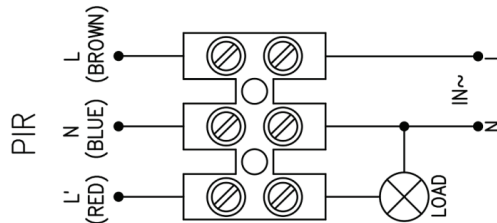

Figure 2

CONNECTION-WIRE DIAGRAM



SENSOR INFORMATION

It can detect the front side, bottom side and back side

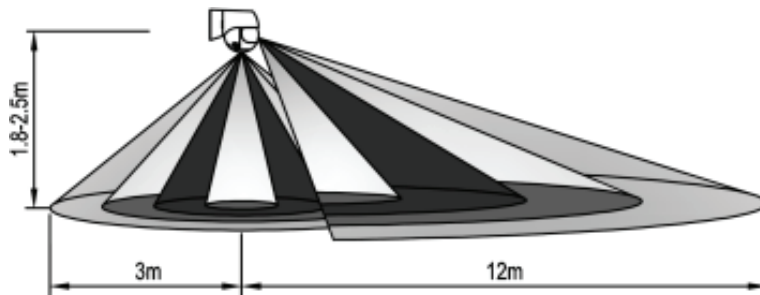

TEST

- Turn the TIME knob anti-clockwise on the minimum (10s). Turn the LUX knob clockwise on the maximum (sun).
- Switch on the power; the sensor and its connected lamp will have no signal at the beginning. After Warm-up 30sec, the sensor can start work. If the sensor receives the induction signal, the lamp will turn on. While there is no another induction signal any more, the load should stop working within $10\text{sec} \pm 3\text{sec}$ and the lamp would turn off.

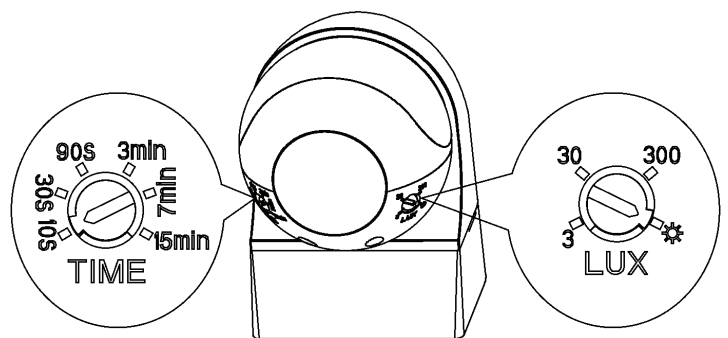

- Turn LUX knob anti-clockwise on the minimum (3). If the ambient light is more than 3LUX, the sensor would not work and the lamp stop working too. If the ambient light is less than 3LUX (darkness), the sensor would work. Under no induction signal condition, the sensor should stop working within $10\text{sec} \pm 3\text{sec}$.

Note: when testing in daylight, please turn LUX knob to ☀ (sun) position, otherwise the sensor could not work!

TROUBLESHOOTING

- **The load does not work:**

- a. Please check if the connection of power source and load is correct.
- b. Please check if the load is good.
- c. Please check if the settings of working light correspond to ambient light.

- **The sensitivity is poor**

- a. Please check if there is any hindrance in front of the detector to affect it to receive the signals.
- b. Please check if the ambient temperature is too high.
- c. Please check if the induction signal source is in the detection field.
- d. Please check if the installation height corresponds to the height required in the instruction.
- e. Please check if the moving orientation is correct.

- **The sensor can not shut off the load automatically**

- a. Please check if there is continual signal in the detection field.
- b. Please check if the time delay is set to the maximum position.
- c. Please check if the power corresponds to the instruction.



V-TAC WEST EUROPE LTD. IN CASE OF ANY QUERY/ISSUE WITH THE PRODUCT, PLEASE REACH OUT TO US AT:
SUPPORT@V-TAC.EU FOR MORE PRODUCTS RANGE, INQUIRY PLEASE CONTACT OUR DISTRIBUTOR OR NEAREST DEALERS.
V-TAC WEST EUROPE LTD. GROUND FLOOR, 71 LOWER BAGGOT STREET, DUBLIN 02, IRELAND D02 P593

V-TAC UK LTD. IN CASE OF ANY QUERY/ISSUE WITH THE PRODUCT PLEASE REACH OUT TO US AT
SUPPORT@VTACEXPORTS.COM V-TAC, 5A TUNGSTEN PARK, DOWNS ROAD, WITNEY, OXFORDSHIRE, OX29 OAX
