



Meaningful Innovation.

WEEE Number: 80133970

# INSTALLATION INSTRUCTION

## REAL PIR PRESENCE SENSOR

### TECHNICAL DATA

MODEL	VT-81005
SKU	24113
RATED LOAD	[Traditional Lighting] 2000W [LED Lighting] 1000W
INPUT VOLTAGE	220-240V/AC
POWER FREQUENCY	50/60Hz
AMBIENT LIGHT	<3-2000 LUX (Adjustable)
TIME DELAY	Min. 10sec±3sec Max. 15min±2min
DETECTION RANGE	360°
DETECTION DISTANCE	2-6m (diamter) Adjustable
WORKING TEMPERATURE	-20~+40°C
WORKING HUMIDITY	<93%RH
INSTALLATION HEIGHT	2.2-4m
POWER CONSUMPTION	Approx 0.5W
DETECTION MOTION SPEED	0.6-1.5m/s
IP RATING	IP20
DIMENSION	Ø115x24.3mm



**05** YEAR  
**WARRANTY\***

**COMPATIBLE WITH**  
**V-TAC LED**  
RANGE [UPTO 1000W]

### INTRODUCTION & WARRANTY

Thank you for selecting and buying V-TAC product. V-TAC will serve you the best. Please read these instructions carefully before starting the installing and keep this manual handy for future reference. If you have any another query, please contact our dealer or local vendor from whom you have purchased the product. They are trained and ready to serve you at the best. The warranty is valid for 5 years from the date of purchase. The warranty does not apply to damage caused by incorrect installation or abnormal wear and tear. The company gives no warranty against damage to any surface due to incorrect removal and installation of the product. The products are suitable for 10-12 Hours Daily operation. Usage of product for 24 Hours a day would void the warranty. This product is warranted for manufacturing defects only.

### WARNING

- Please make sure to turn off the power before starting the installation.
- Installation should only be done by a certified electrician.
- For indoor use only.

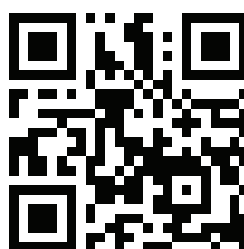

### MULTI-LANGUAGE MANUAL QR CODE

Please scan the QR code to access the manual in multiple languages.



This marking indicates that this product should not be disposed of with other household wastes.

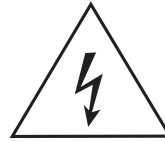

Caution, risk of electric shock.

## FUNCTION

- Can identify day and night: The consumer can adjust working state in different ambient light. It can work in the daytime and at night when it is adjusted on the "sun" position (max). It can work in the ambient light less than 3LUX when it is adjusted on the "3" position (min). As for the adjustment pattern, please refer to the testing pattern.
- SENS adjustable: It only works for presence detection. When set knob to "+", it's high sensitivity, the presence detection distance could be 6m in diameter which fit to a large room. When set knob to "-", the presence detection distance of low sensitivity is only within 2m in diameter.
- Time-Delay is added continually: When it receives the second induction signals within the first induction, it will restart to time from the moment.

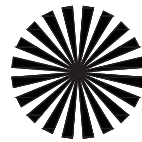

## INSTALLATION ADVICE

As the detector responds to changes in temperature, avoid the following situations:

- Avoid pointing the detector towards objects with highly reflective surfaces, such as mirrors etc.
- Avoid mounting the detector near heat sources, such as heating vents, air conditioning units, light etc.
- Avoid pointing the detector towards objects that may move in the wind, such as curtains, tall plants etc.

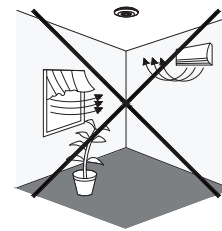
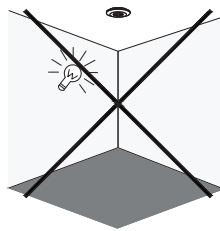
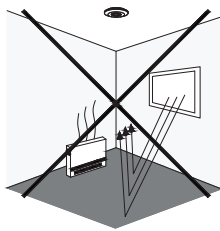

## INSTALLATION DIAGRAM

- Switch off the power.
- Please move the upper cover with anti-clockwise whirl as per the diagram on the right.
- Connect the power and the load according to the connection-wire diagram.
- Fix the bottom on the selected position with the inflated screw.
- Install back the upper cover on the sensor, then you could switch on the power and test it.

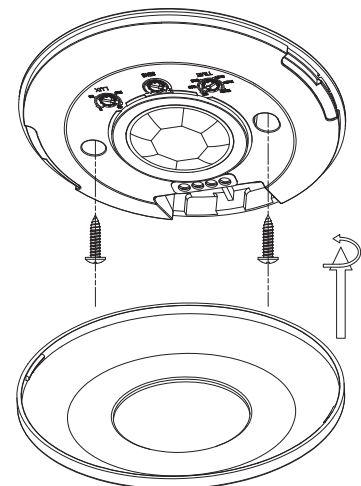

## CONNECTION-WIRE DIAGRAM

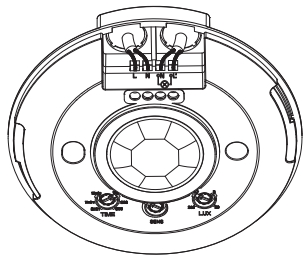

The wires come in and out from the bottom

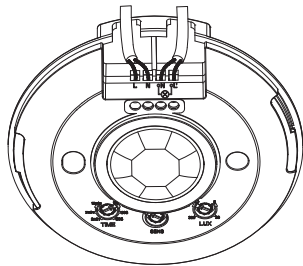
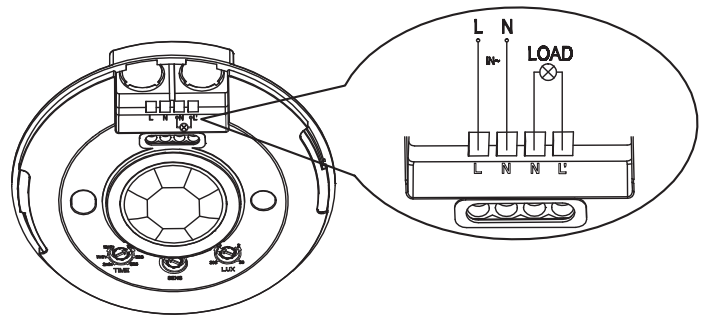

The wires come in and out from the side

## SENSOR INFORMATION

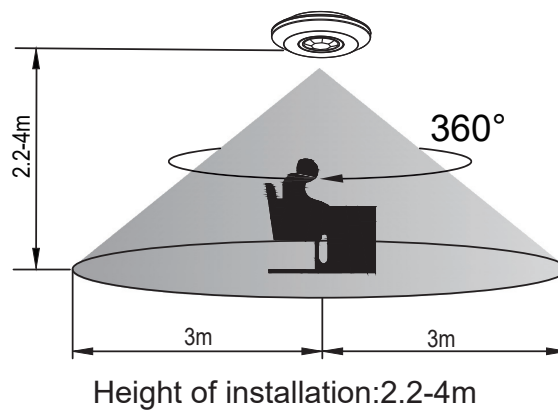

## TEST

- Turn the TIME knob anti-clockwise on the minimum (10s). Turn the SENS knob clockwise on the maximum (+). Turn the LUX knob clockwise on the maximum (sun).
- Switch on the power; the sensor and it's connected lamp will have no signal at the beginning. After Warm-up 30sec, the sensor can start work .If the sensor receives the induction signal, it will enter sensor mode.
- Turn LUX knob anti-clockwise on the minimum (3). If the ambient light is more than 3LUX, the sensor would not work and the lamp stop working too. If the ambient light is less than 3LUX (darkness), the sensor would work. Under no induction signal condition, the sensor should stop working within 10sec±3sec.

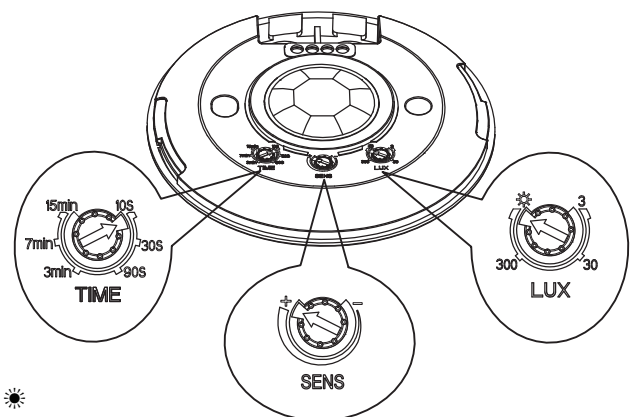

**Note:** when testing in daylight, please turn LUX knob to ☀ (SUN) position, otherwise the sensor lamp could not work! If the lamp is more than 60W, the distance between lamp and sensor should be 60cm at least.

---

## TROUBLESHOOTING

- **The load does not work**

- a. Please check if the connection of power source and load is correct.
- b. Please check if the load is good.
- c. Please check if the settings of working light correspond to ambient light.

- **The sensitivity is poor**

- a. Please check if there is any hindrance in front of the detector to affect it to receive the signals.
- b. Please check if the induction signal source is in the detection field.
- c. Please check if the installation height corresponds to the height required in the instruction.
- d. Please check if the moving orientation is correct.

- **The sensor can not shut off the load automatically**

- a. Please check if there is continual signal in the detection field.
- b. Please check if the time delay is set to the maximum position
- c. Please check if the power corresponds to the instruction.



**V-TAC WEST EUROPE LTD.** IN CASE OF ANY QUERY/ISSUE WITH THE PRODUCT, PLEASE REACH OUT TO US AT:  
SUPPORT@V-TAC.EU FOR MORE PRODUCTS RANGE, INQUIRY PLEASE CONTACT OUR DISTRIBUTOR OR NEAREST DEALERS.  
V-TAC WEST EUROPE LTD. GROUND FLOOR, 71 LOWER BAGGOT STREET, DUBLIN O2, IRELAND DO2 P593

**V-TAC UK LTD.** IN CASE OF ANY QUERY/ISSUE WITH THE PRODUCT PLEASE REACH OUT TO US AT  
SUPPORT@VTACEXPORTS.COM V-TAC, 5A TUNGSTEN PARK, DOWNS ROAD, WITNEY, OXFORDSHIRE, OX29 OAX

---