

MX2-EV2

Born to drive machines

- Current vector control
- High starting torque: 200% at 0.5 Hz
- Double rating VT 120%/1 min and CT 150%/1 min
- IM & PM motor control
- Torque control in open loop vector
- Positioning functionality
- Built-in application functionality (i.e. Brake control)
- Built-in logic programing
- Safety embedded compliant with ISO13849-1 (double input circuit and external device monitor EDM)
- USB port for PC programming
- 24 VDC backup supply for control board
- Fieldbus communications: EtherCAT
- Built-in RS485
- PC configuration tool: CX-Drive
- RoHS, CE, cULus

Ratings

- 200 V Class single-phase 0.1 to 2.2 kW
- 200 V Class three-phase 0.1 to 15.0 kW
- 400 V Class three-phase 0.4 to 15.0 kW



System configuration

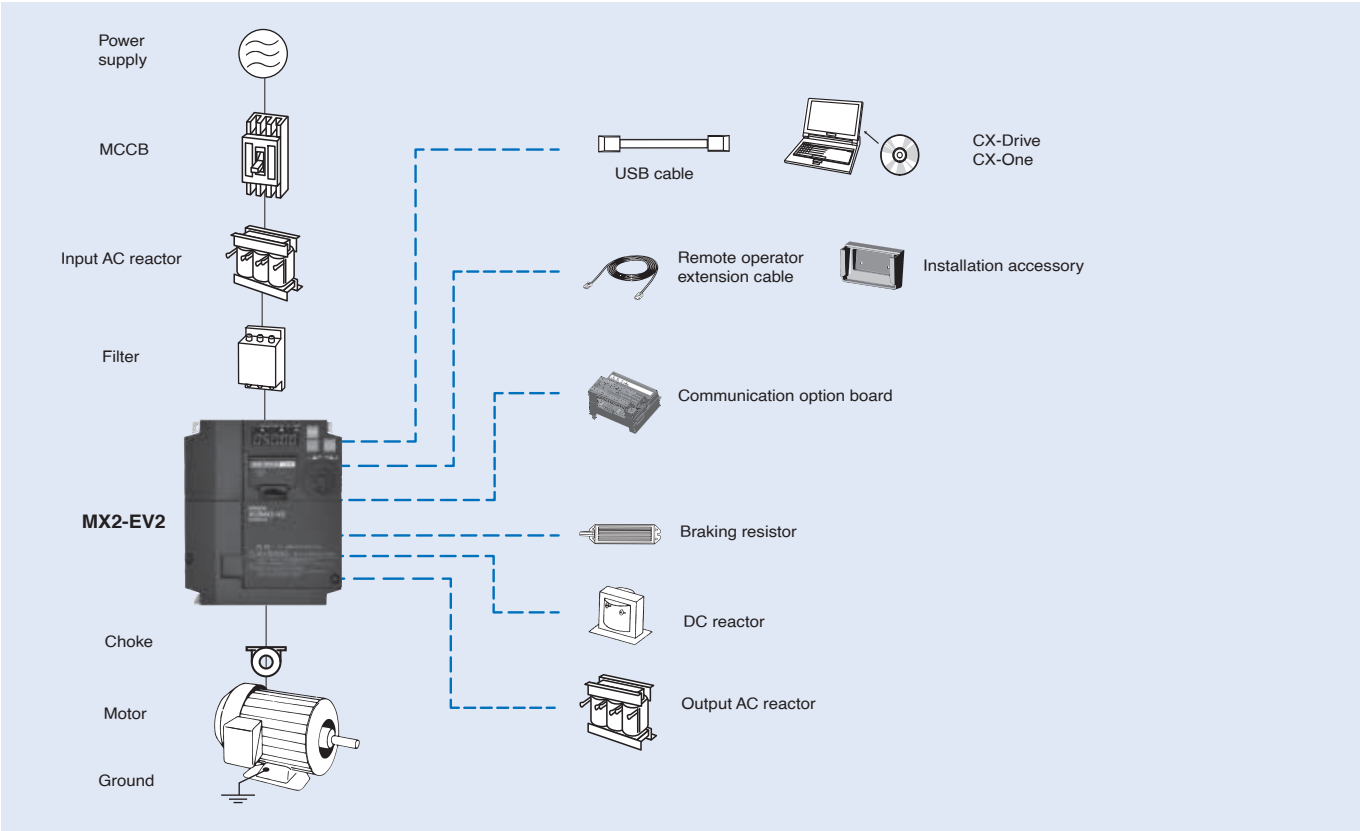

Specifications

Type designation

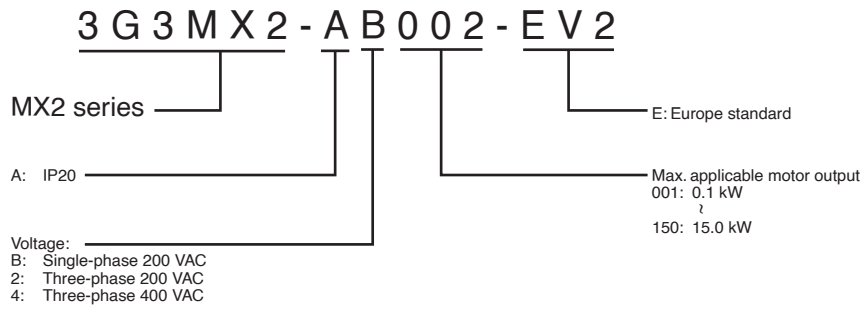

200 V class

Single-phase: 3G3MX2-EV2@		B001	B002	B004	B007	B015	B022	-	-	-	-	-	
Three-phase: 3G3MX2-EV2@		2001	2002	2004	2007	2015	2022	2037	2055	2075	2110	2150	
Motor kW ^{*1}	For VT setting	0.2	0.4	0.55	1.1	2.2	3.0	5.5	7.5	11	15	18.5	
	For CT setting	0.1	0.2	0.4	0.75	1.5	2.2	3.7	5.5	7.5	11	15	
Output characteristics	Drive capacity kVA	200 VT	0.4	0.6	1.2	2.0	3.3	4.1	6.7	10.3	13.8	19.3	23.9
		200 CT	0.2	0.5	1.0	1.7	2.7	3.8	6.0	8.6	11.4	16.2	20.7
		240 VT	0.4	0.7	1.4	2.4	3.9	4.9	8.1	12.4	16.6	23.2	28.6
		240 CT	0.3	0.6	1.2	2.0	3.3	4.5	7.2	10.3	13.7	19.5	24.9
	Rated output current (A) at VT	1.2	1.9	3.5	6.0	9.6	12.0	19.6	30.0	40.0	56.0	69.0	
	Rated output current (A) at CT	1.0	1.6	3.0	5.0	8.0	11.0	17.5	25.0	33.0	47.0	60.0	
	Max. output voltage	Proportional to input voltage: 0..240 V											
Max. output frequency	400 Hz												
Power supply	Rated input voltage and frequency	Single-phase 200..240 V 50/60 Hz 3-phase 200..240 V 50/60 Hz											
	Allowable voltage fluctuation	-15%..+10%											
	Allowable frequency fluctuation	5%											
	Rated input current	VT	2.0	3.6	7.3	13.8	20.2	24.0	-				
		CT	1.3	3.0	6.3	11.5	16.8	22.0	-				
Rated input current 3-phase	VT	1.2	1.9	3.9	7.2	10.8	13.9	23.0	37.0	48.0	68.0	72.0	
	CT	1.0	1.6	3.3	6.0	9.0	12.7	20.5	30.8	39.6	57.1	62.6	
Braking	Torque at short-time deceleration by capacitors	100%: <50Hz 50%: <60Hz					70%: <50Hz 50%: <60Hz		Approx 20%		-		
	Min resistor	100			50			35		20		17	
Cooling method		Self cooling					Forced-air-cooling						

*1. Based on a standard 3-Phase standard motor.

400 V class

Three-phase: 3G3MX2-@		4004	4007	4015	4022	4030	4040	4055	4075	4110	4150		
Motor kW ^{*1}	For VT setting	0.75	1.5	2.2	3.0	4.0	5.5	7.5	11	15	18.5		
	For CT setting	0.4	0.75	1.5	2.2	3.0	4.0	5.5	7.5	11	15		
Output characteristics	Drive capacity kVA	380 VT	1.3	2.6	3.5	4.5	5.7	7.3	11.5	15.1	20.4	25.0	
		380 CT	1.1	2.2	3.1	3.6	4.7	6.0	9.7	11.8	15.7	20.4	
		480 VT	1.7	3.4	4.4	5.7	7.3	9.2	14.5	19.1	25.7	31.5	
		480 CT	1.4	2.8	3.9	4.5	5.9	7.6	12.3	14.9	19.9	25.7	
	Rated output current (A) at VT	2.1	4.1	5.4	6.9	8.8	11.1	17.5	23.0	31.0	38.0		
	Rated output current (A) at CT	1.8	3.4	4.8	5.5	7.2	9.2	14.8	18.0	24.0	31.0		
Max. output voltage	Proportional to input voltage: 0..480 V												
Max. output frequency	400 Hz												
Power supply	Rated input voltage and frequency	3-phase 380..480 V 50/60 Hz											
	Allowable voltage fluctuation	-15%..+10%											
	Allowable frequency fluctuation	5%											
	Rated input current	VT	2.1	4.3	5.9	8.1	9.4	13.3	20.0	24.0	38.0	44.0	
CT		1.8	3.6	5.2	6.5	7.7	11.0	16.9	18.8	29.4	35.9		
Braking	Torque at short-time deceleration by capacitors	100%: <50Hz 50%: <60Hz					70%: <50Hz 50%: <60Hz		-				
	Min resistor	180			100			70			35		
Cooling method		Self cooling					Forced-air-cooling						

*1. Based on a standard 3-Phase standard motor.

Specifications

Common specifications

Model number 3G3MX2		Specifications
Control functions	Control methods	Phase-to-phase sinusoidal pulse with modulation PWM (Sensorless vector control, V/F)
	Output frequency range	0.10..590.00 Hz
	Frequency precision	Digital set value: $\pm 0.01\%$ of the max. frequency Analogue set value: $\pm 0.2\%$ of the max. frequency ($25 \pm 10^\circ\text{C}$)
	Resolution of frequency set value	Digital set value: 0.01 Hz Analogue set value: 1/1000 of maximum frequency
	Resolution of output frequency	0.01Hz
	Starting torque	200% / 0.5 Hz
	Overload capability	Dual rating: Heavy duty (CT): 150% for 1 minute Normal Duty (VT): 120% for 1 minute
	Frequency set value	0 to 10 VDC (10 K Ω), 4 to 20 mA (100 Ω), RS485 Modbus, Network options
	V/f Characteristics	Constant/ reduced torque, free V/f
Functionality	Inputs signals	FW (forward run command), RV (reverse run command), CF1~CF4 (multi-stage speed setting), JG (jog command), DB (external braking), SET (set second motor), 2CH (2-stage accel./decel. command), FRS (free run stop command), EXT (external trip), USP (startup function), CS (commercial power switchover), SFT (soft lock), AT (analog input selection), RS (reset), PTC (thermistor thermal protection), STA (start), STP (stop), F/R (forward/reverse), PID (PID disable), PIDC (PID reset), UP (remote control up function), DWN (remote control down function), UDC (remote control data clear), OPE (operator control), SF1~SF7 (multi-stage speed setting; bit operation), OLR (overload restriction), TL (torque limit enable), TRQ1 (torque limit changeover1), TRQ2 (torque limit changeover2), BOK (Braking confirmation), LAC (LAD cancellation), PCLLR (position deviation clear), ADD (add frequency enable), F-TM (force terminal mode), ATR (permission of torque command input), KHC (Cumulative power clear), MI1~MI7 (general purpose inputs for Drive Programming), AHD (analog command hold), CP1~CP3 (multistage-position switches), ORL (limit signal of zero-return), ORC (trigger signal of zero-return), SPD (speed/position changeover), 485 (Starting communication signal), PRG (executing Drive Programming), HLD (retain output frequency), ROK (permission of run command), EB (rotation direction detection of B phase), DISP (display limitation), OP (option control signal), NO (no function), PSET (preset position)
	Output signals	RUN (run signal), FA1~FA5 (frequency arrival signal), OL,OL2 (overload advance notice signal), OD (PID deviation error signal), AL (alarm signal), OTQ (over/under torque threshold), UV (under-voltage), TRQ (torque limit signal), RNT (run time expired), ONT (power ON time expired), THM (thermal warning), BRK (brake release), BER (brake error), ZS (0Hz detection), DSE (speed deviation excessive), POK (positioning completion), ODc (analog voltage input disconnection), OIdc (analog current input disconnection), FBV (PID second stage output), NDc (network disconnect detection), LOG1~LOG3 (Logic output signals), WAC (capacitor life warning), WAF (cooling fan warning), FR (starting contact), OHF (heat sink overheat warning), LOC (Low load), MO1~MO3 (general outputs for Drive Programming), IRDY (drive ready), FWR (forward operation), RVR (reverse operation), MJA (major failure), WCO (window comparator O), WCOI (window comparator OI), FREF (frequency command source), REF (run command source), SETM (second motor in operation), EDM (STO (safe torque off) performance monitor), OP (option control signal), NO (no function)
	Standard functions	Free-V/f, manual/automatic torque boost, output voltage gain adjustment, AVR function, reduced voltage start, motor data selection, auto-tuning, motor stabilization control, reverse running protection, simple position control, simple torque control, torque limiting, automatic carrier frequency reduction, energy saving operation, PID function, non-stop operation at instantaneous power failure, brake control, DC injection braking, dynamic braking (BRD), frequency upper and lower limiters, jump frequencies, curve accel and decel (S, U, inverted U,EL-S), 16-stage speed profile, fine adjustment of start frequency, accel and decel stop, process jogging, frequency calculation, frequency addition, 2-stage accel/decel, stop mode selection, start/end freq., analog input filter, window comparators, input terminal response time, output signal delay/hold function, rotation direction restriction, stop key selection, software lock, safe stop function, scaling function, display restriction, password function, user parameter, initialization, initial display selection, cooling fan control, warning, trip retry, frequency pull-in restart, frequency matching, overload restriction, over current restriction, DC bus voltage AVR
	Analogue inputs	2 analogue inputs 0 to 10 V (10 K Ω), 4 to 20 mA (100 Ω)
	Pulse train input terminal	0 to 24 V, up to 32 kHz
	Accel/Decel times	0.01 to 3600.0 s (line/curve selection), 2nd accel/decel setting available
	Display	Status indicator LED's Run, Program, Alarm, Power, Hz, Amps Digital operator: Available to monitor 32 items: frequency reference, output current, output frequency...
	Motor overload protection	Electronic Thermal overload relay and PTC thermistor input
	Instantaneous overcurrent	200% of rated current
	Overload	Dual rating: Heavy duty (CT): 150% for 1 minute Normal Duty (VT): 120% for 1 minute
Overvoltage	800 V for 400 V type and 400 V for 200 V type	
Undervoltage	345 V for 400 V type and 172.5 V for 200 V type	
Momentary power loss	Following items are selectable: Alarm, decelerates to stop, decelerates to stop with DC bus controlled, restart	
Cooling fin overheat	Temperature monitor and error detection	
Stall prevention level	Stall prevention during acceleration/deceleration and constant speed	
Ground fault	Detection at power-on	
Power charge indication	On when power is supplied to the control part	
Ambient conditions	Degree of protection	IP20
	Ambient humidity	90% RH or less (without condensation)
	Storage temperature	-20°C..+65°C (short-term temperature during transportation)
	Ambient temperature	• 10°C to 50°C (Both the carrier frequency and output current need to be reduced over 40°C)
	Installation	Indoor (no corrosive gas, dust, etc.)
	Installation height	Max. 1000 m
Vibration	5.9 m/s ² (0.6G), 10 to 55 Hz	

Dimensions

Standard models

Fig.1

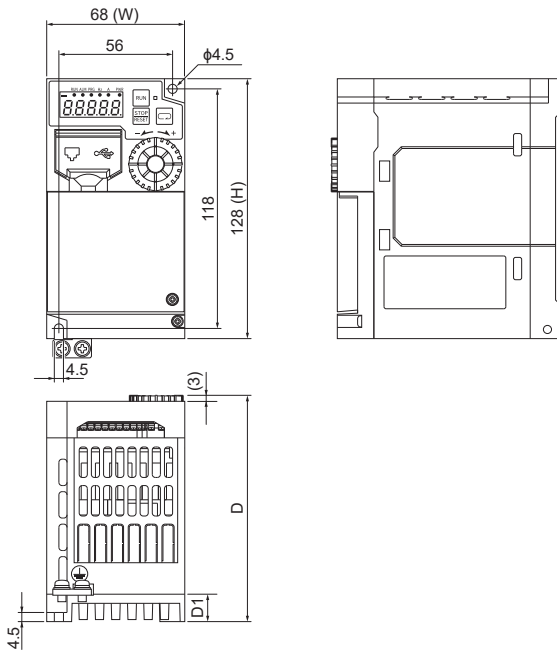

Fig.2

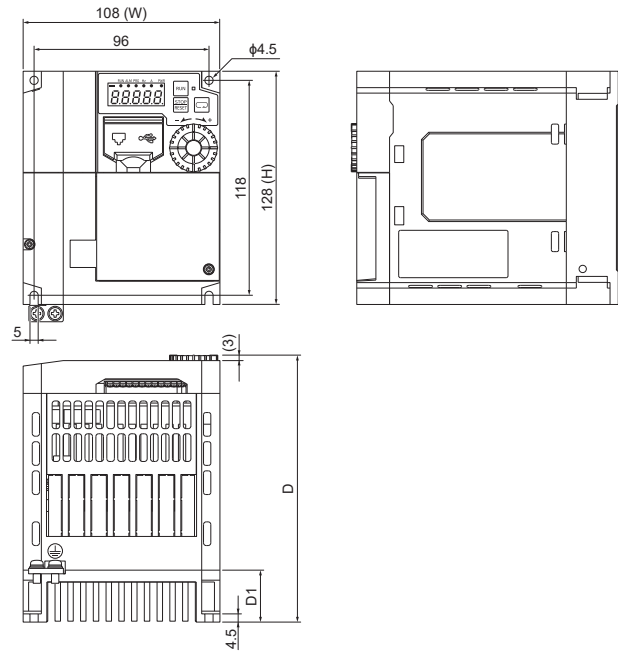

Fig.3

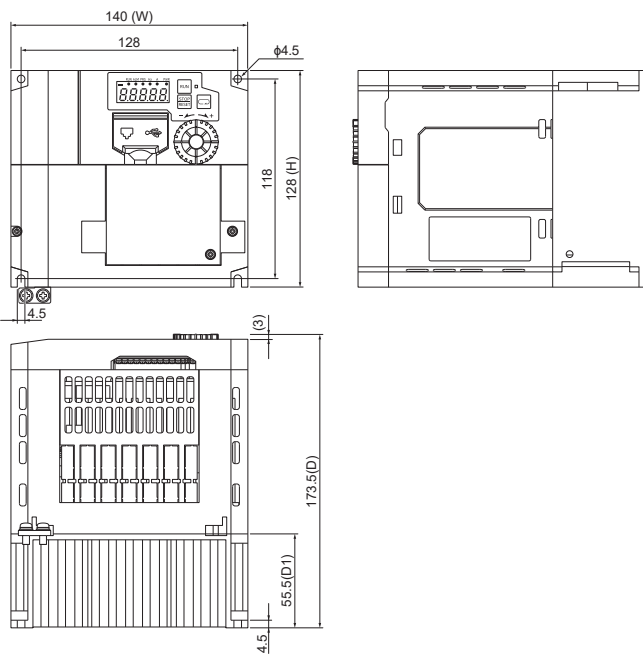

Fig.4

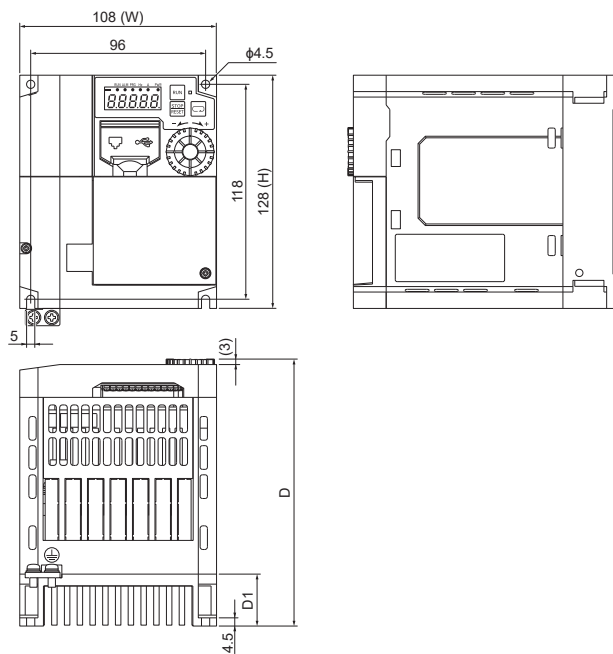

Fig.5

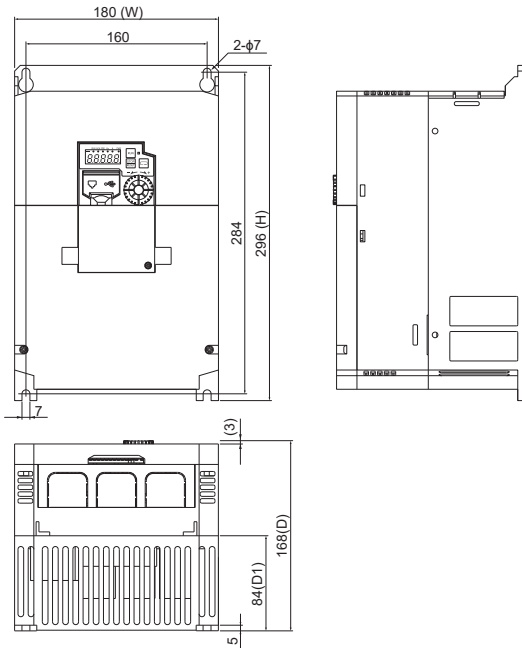
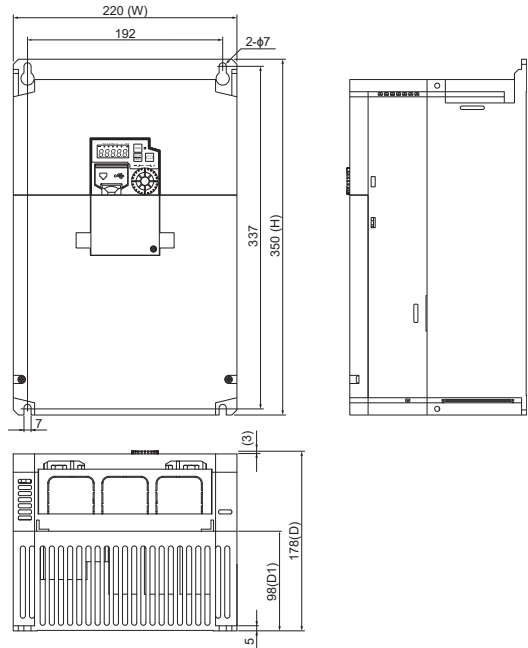

Fig.6



Voltage class	Drive model 3G3MX2-A@	Figure	Dimensions in mm									
			W	W1	H	H1	t	D	D1	D2	d	Weight (kg)
Single-phase 200 V	B001-EV2	1	68	56	128	118	-	112	13.5	-	-	1.0
	B002-EV2								27			
	B004-EV2								27			
	B007-EV2	2	108	96	128	118	-	125.5	27	4.4	4.5	1.1
	B015-EV2								55			1.6
B022-EV2	55	1.8										
Three-phase 200 V	2001-EV2	1	68	56	128	118	-	112	13.5	-	-	1.0
	2002-EV2								27			
	2004-EV2								27			
	2007-EV2	2	108	96	128	118	-	148.5	50	4.4	4.5	1.6
	2015-EV2								55			1.8
	2022-EV2	55	1.8									
	2037-EV2	3	140	128	128	118	5	178	98	-	-	2.0
	2055-EV2	4	122	260	248	248	6	158	73.3	6	6	3.5
	2075-EV2	5	180	160	296	284	7	168	84	5	7	4.5
	2110-EV2								84			
2150-EV2	98								6.5			
Three-phase 400 V	4004-EV2	2	108	96	128	118	-	146.5	28	-	-	1.5
	4007-EV2							55	1.8			
	4015-EV2							55	1.8			
	4022-EV2	3	140	128	128	118	5	173.5	55	4.4	4.5	2.0
	4030-EV2								55			
	4040-EV2	4	122	260	248	248	6	158	73.3	6	6	3.5
	4055-EV2								73.3			
	4075-EV2	5	180	160	296	284	7	168	97	5	7	4.5
4110-EV2	97											
4150-EV2	97											

Line filters

AX-FIC1010-SE

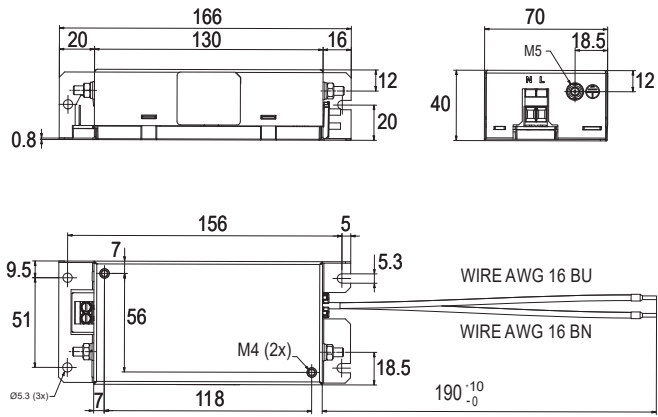

AX-FIC1020-SE

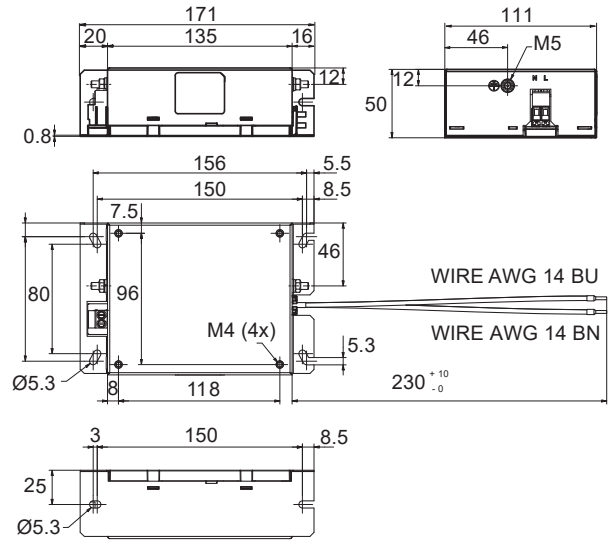

AX-FIM1024-SE

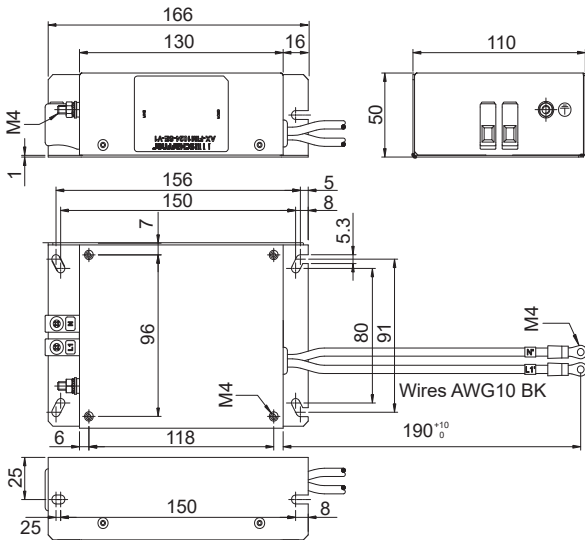

AX-FIC1030-SE

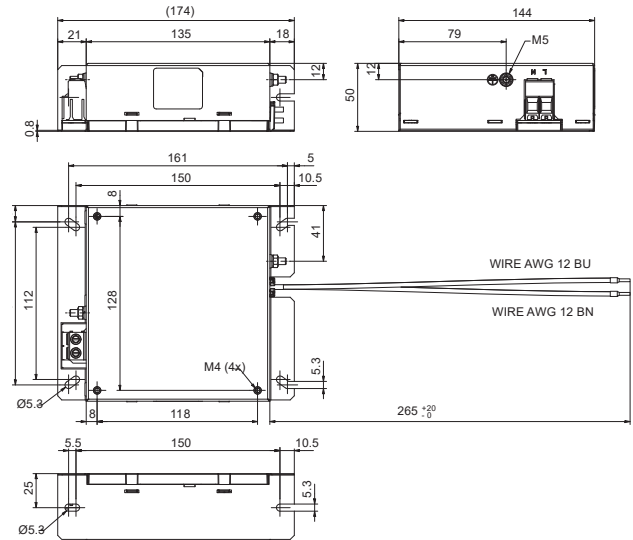

AX-FIC4005-SE

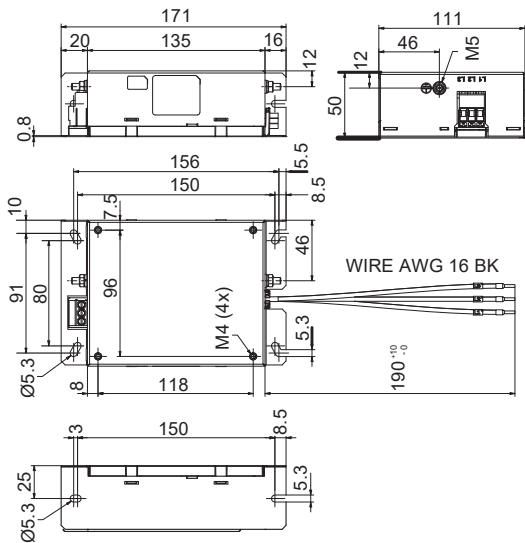

AX-FIC4010-SE

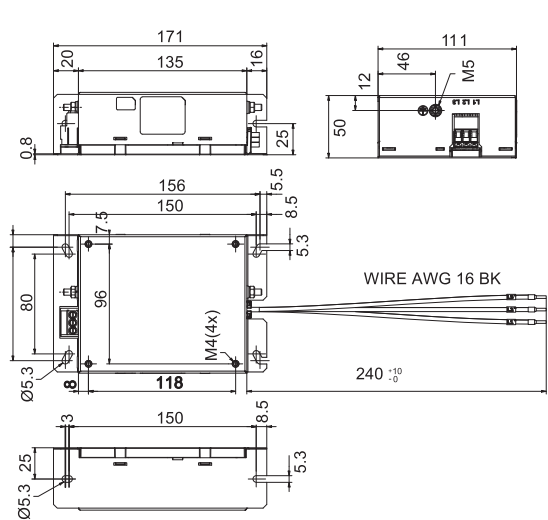

AX-FIC4015-SE

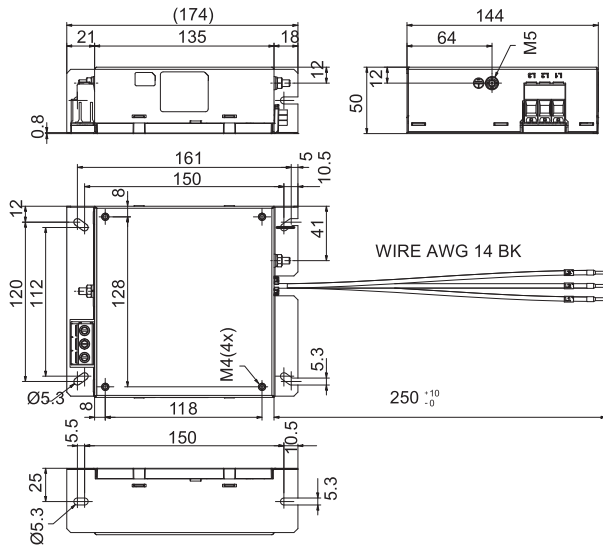

AX-FIC4030-SE

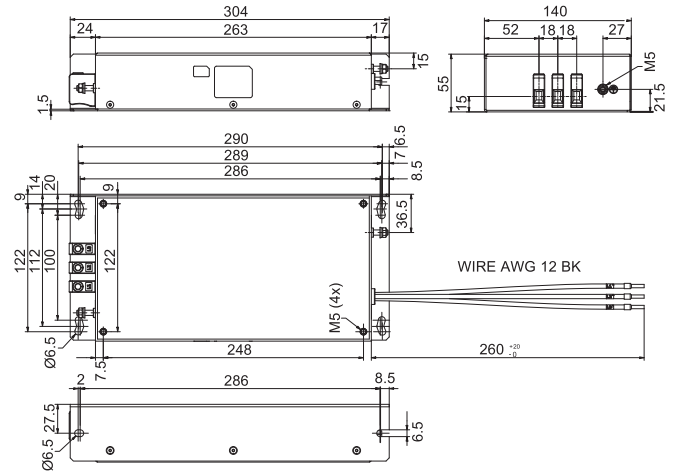

AX-FIC4050-SE

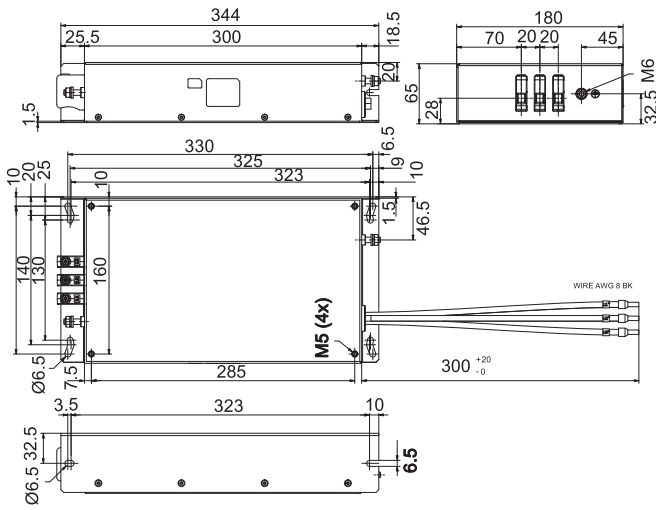

AX-FIC4080-SE

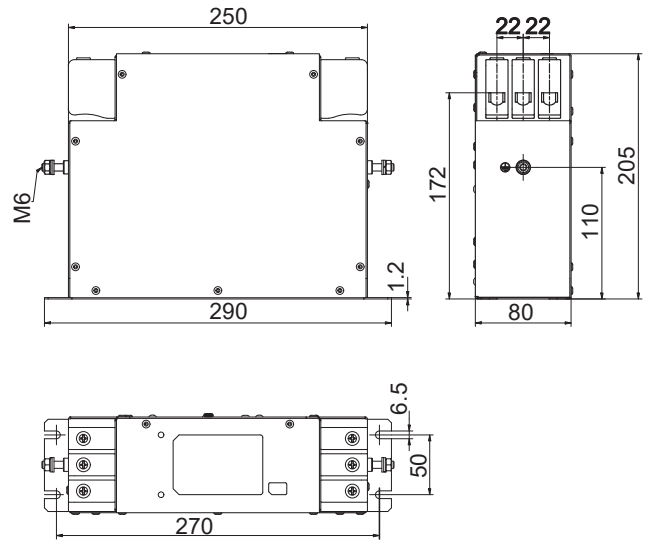

Note: LL filters has same dimensions than standard ones.

Input AC Reactor

Voltage	Reference	Dimensions								Weight (kg)
		A	B	C	D	E	F	G	H	
Single phase 200 V	AX-RAI02000070-DE	84	113	96	101	66	5	7.5	2	1.22
	AX-RAI01700140-DE	84	113	116	101	66	5	7.5	2	1.95
	AX-RAI01200200-DE	84	113	131	101	66	5	7.5	2	2.55
	AX-RAI00630240-DE	84	113	116	101	66	5	7.5	2	1.95

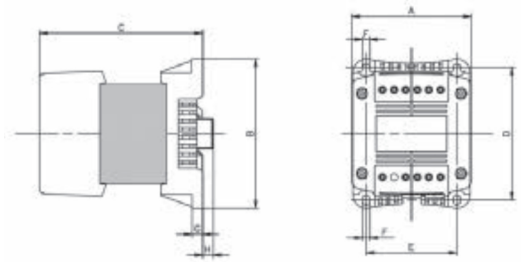

Voltage	Reference	Dimensions						Weight (kg)
		A	B2	C2	D	E	F	
Three phase 200 V	AX-RAI02800080-DE	120	70	120	80	52	5.5	1.75
	AX-RAI00880200-DE	120	80	120	80	62	5.5	2.35
	AX-RAI00350335-DE	180	85	190	140	55	6	5.5
	AX-RAI00180670-DE	180	85	190	140	55	6	5.5
Three phase 400 V	AX-RAI07700050-DE	120	70	120	80	52	5.5	1.78
	AX-RAI03500100-DE	120	80	120	80	62	5.5	2.35
	AX-RAI01300170-DE	120	80	120	80	62	5.5	2.50
	AX-RAI00740335-DE	180	85	190	140	55	6	5.5

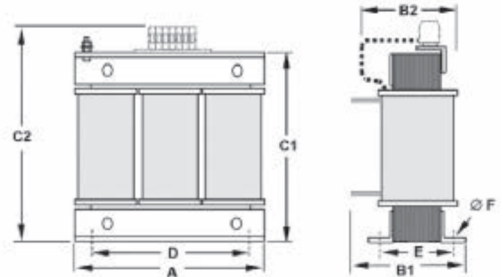

DC Reactor

Voltage	Reference	Dimensions								Weight (kg)	
		A	B	C	D	E	F	G	H		
200 V	AX-RC21400016-DE	84	113	96	101	66	5	7.5	2	1.22	
	AX-RC10700032-DE			105						1.60	
	AX-RC06750061-DE			116						1.95	
	AX-RC02510138-DE			108						135	124
	AX-RC01110309-DE	120	152	136	135	94	7	-	-	5.20	
	AX-RC00840437-DE	-	-	146	-	-	-	2	-	6.00	
	AX-RC00590614-DE	150	177	160	160	115	-	-	-	11.4	
	AX-RC00440859-DE	-	-	182.6	-	-	-	-	-	14.3	
	400 V	AX-RC43000020-DE	84	113	96	101	66	5	7.5	2	1.22
		AX-RC27000030-DE			105						1.60
AX-RC14000047-DE		116			1.95						
AX-RC10100069-DE		108			135						133
AX-RC06400116-DE		120	152	136	135	94	7	-	-	5.20	
AX-RC04410167-DE		-	-	146	-	-	-	2	-	6.00	
AX-RC03350219-DE		150	177	160	160	115	-	-	-	11.4	
AX-RC02330307-DE		-	-	183	-	-	-	-	-	14.3	

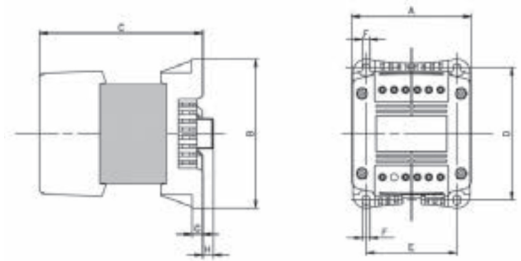

Output Reactor

Voltage	Reference	Dimensions						Weight (kg)		
		A	B2	C2	D	E	F			
200 V	AX-RAO11500026-DE	120	70	120	80	52	5.5	1.78		
	AX-RAO07600042-DE		70							
	AX-RAO04100075-DE		80							
	AX-RAO03000105-DE	80				62	2.35			
	AX-RAO01830180-DE	180	85	195	140	55	6	5.5		
	AX-RAO01150220-DE		85							
	AX-RAO00950320-DE		85	210						
	AX-RAO00630430-DE		95						65	9.1
	AX-RAO00490640-DE		105						75	11.7
400 V	AX-RAO16300038-DE	120	80	120	80	62	5.5	2.35		
	AX-RAO11800053-DE		80							
	AX-RAO07300080-DE	180	95	195	140	55	6	5.5		
	AX-RAO04600110-DE		85							
	AX-RAO03600160-DE		85	210					65	6.5
	AX-RAO02500220-DE		95						65	9.1
	AX-RAO02000320-DE		240						110	275

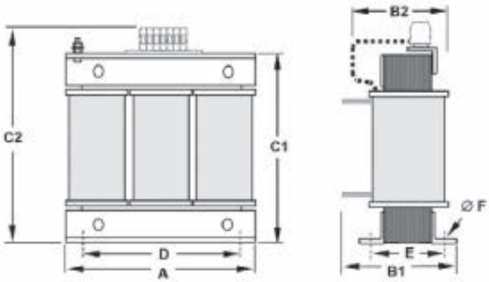

Chokes

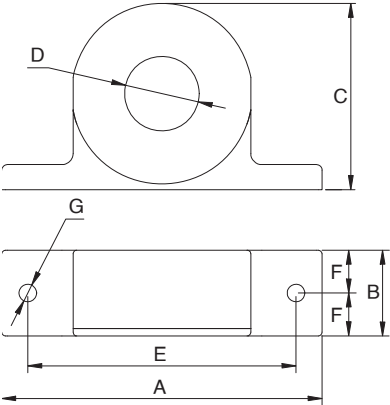

Figure 1

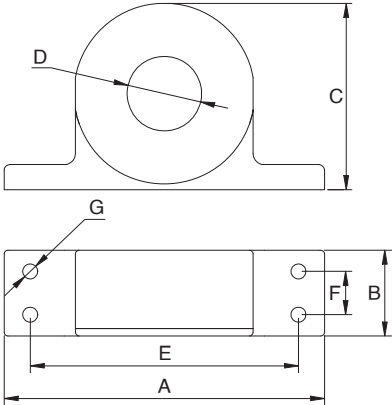

Figure 2

Reference	Fig	D (diameter)	Motor (kW)	Dimensions (mm)							Weight (kg)
				A	B	C	D	E	F	G (diameter)	
AX-FER2102-PE	1	21	< 2.2	86	24	50	21	70	12	4	0.09
AX-FER2815-PE		28	< 15	106	25	65	28	90	12.5		0.22
AX-FER5045-PE	2	50	< 45	150	51	112	50	125	30	5	0.53

Resistor dimensions

AX-REM00K1400-IE

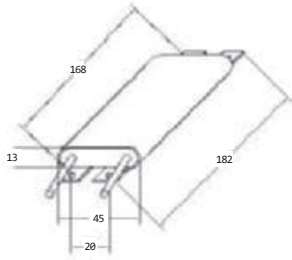

Fig 1

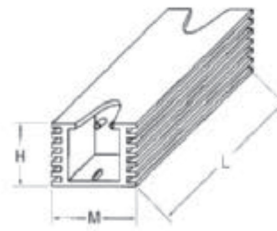

Fig 2

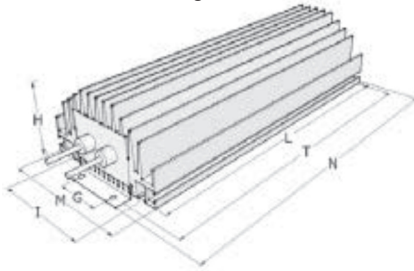

Fig 3

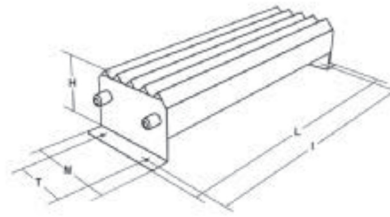
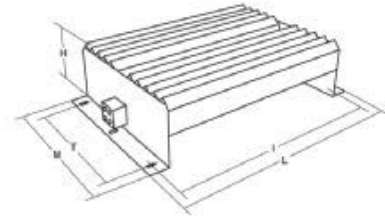
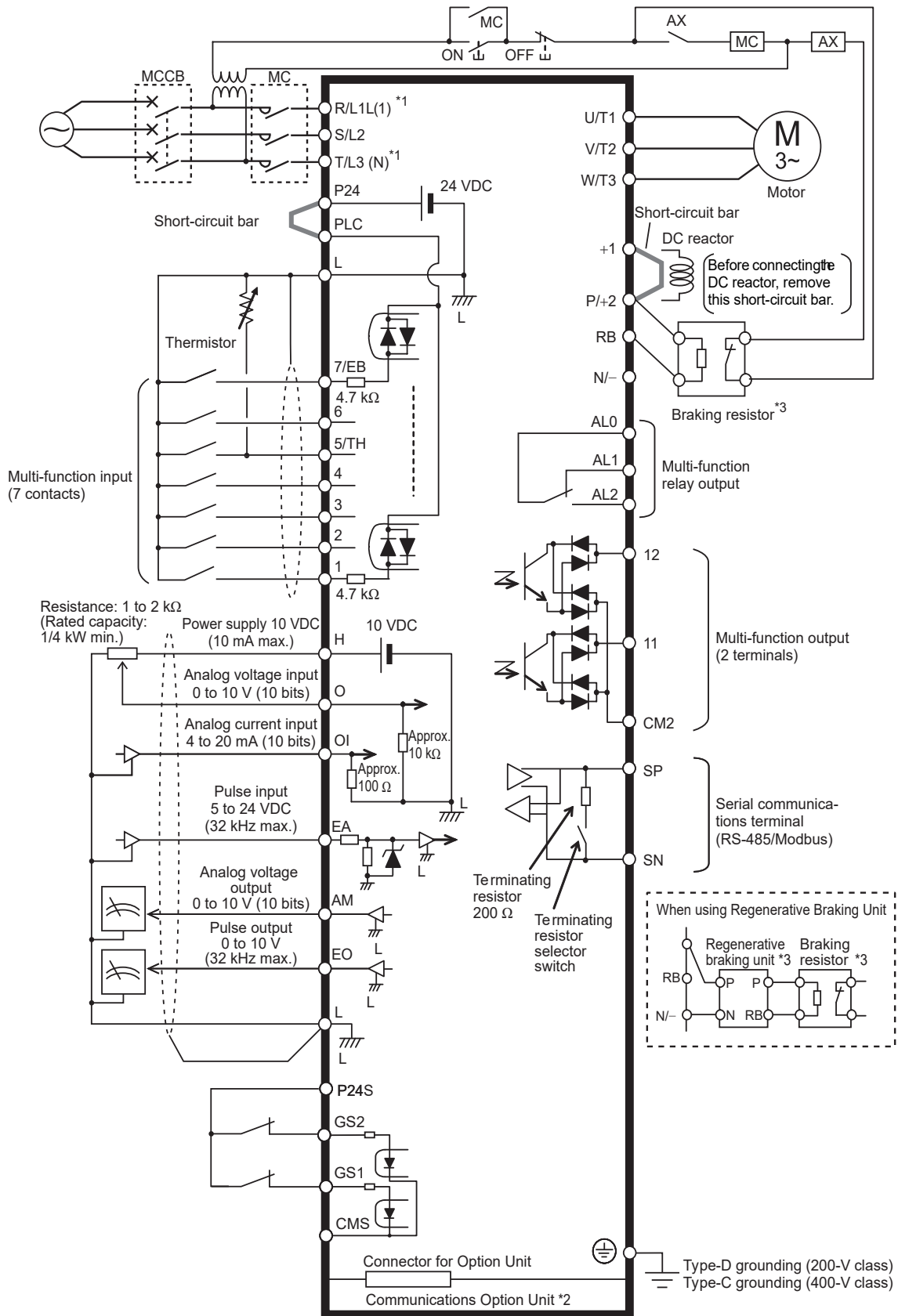

Fig 4



Type	Fig.	Dimensions							Weight (kg)					
		L	H	M	I	T	G	N						
AX-REM00K2070-IE	1	105	27	36	94	-	-	-	0.2					
AX-REM00K2120-IE		200	27		189	-	-	-						
AX-REM00K2200-IE					249									
AX-REM00K4075-IE		260	27	309										
AX-REM00K4035-IE				320										
AX-REM00K4030-IE		2	200	61	100				74.5	216	40	230	1.41	
AX-REM00K5120-IE			73	260					27					249
AX-REM00K6100-IE														
AX-REM00K6035-IE		3	365	105	350				70	-	-	-	4	
AX-REM00K9070-IE														
AX-REM00K9020-IE														
AX-REM00K9017-IE	4	310	100	240	295	210	-	-	7					
AX-REM01K9070-IE														
AX-REM01K9017-IE														
AX-REM02K1070-IE	365	310	100	240	295	210	-	-	8					
AX-REM02K1017-IE														
AX-REM03K5035-IE	365													

Standard connections



Terminal Block Specifications

Terminal	Name	Function (signal level)
R/L1, S/L2, T/L3	Main circuit power supply input	Used to connect line power to the drive. Drives with single-phase 200 V input power use only terminals R/L1 and N (T/L3), terminal S/L2 is not available for these units
U/T1, V/T2, W/T3	Drive output	Used to connect the motor
PD/+1, P/+	External DC reactor terminal	Normally connected by the short-circuit bar. Remove the short-circuit bar between +1 and P/+2 when a DC reactor is connected.
P/+, N/-	Regenerative braking unit terminal	Connect optional regenerative braking units (If a braking torque is required)
P/+, RB	Braking resistor terminals	Connect option braking resistor (if a braking torque is required)
⊕	Grounding	For grounding (grounding should conform to the local grounding code.)

Control Circuit

Type	No.	Signal name	Function	Signal level
Digital input signals	PLC	Intelligent input common	Source type: connecting [P24] to [1]-[7] turns inputs ON Sink type: connecting [L] to [1]-[7] turns inputs ON	-
	P24	Internal 24 VDC	24 VDC, 30mA	24 VDC, 100 mA
	1	Multi-function Input selection 1	Factory setting: Forward/ Stop	27 VDC max
	2	Multi-function Input selection 2	Factory setting: Reverse/ Stop	
	3	Multi-function Input selection 3	Factory setting: External trip	
	4	Multi-function Input selection 4	Factory setting: Reset	
	5/PTC	Multi-function Input selection 5 / PTC thermistor input	Factory setting: Multi-step speed reference 1	
	6	Multi-function input selection 6	Factory setting: Multi-step speed reference 2	
	7/EB	Multi-function input selection 7 / Pulse train input B	Factory setting: Jog	
L	Multi-function Input selection common (in upper row)	-		
Pulse train	EA	Pulse train input A	Factory setting: Speed reference	32 kHz max 5 to 24 VDC
	EO	Pulse train output	LAD frequency	10 VDC 2 mA 32 kHz max
Analog input signal	H	Frequency reference power supply	10 VDC 10 mA max	
	O	Voltage frequency reference signal	0 to 10 VDC (10 kΩ)	
	OI	Current frequency reference signal	4 to 20 mA (100 Ω)	
	L	Frequency reference common (bottom row)	-	
Digital output signals	11/EDM	Discrete logic output 1 / EDM output	Factory setting: During Run	27 VDC, 50 mA max EDM based on ISO13849-1
	12	Discrete logic output 2	Factory setting: Frequency arrival type 1	
	CM2	GND logic output	-	
	AL0	Relay common contact	Factory setting: Alarm signal Under normal operation	R load 250 VAC 2.5 A 30 VDC 3.0 A I load 250 VAC 0.2 A 30 VDC 0.7 A
	AL1	Relay contact, normally open	AL1 - AL0 Closed AL2 - AL0 Open	
AL2	Relay contact, normally closed			
Monitor Signal	AM	Analog voltage output	Factory setting: LAD frequency	0 to 10 VDC 1 mA
Comms	SP	Serial communication terminal	RS485 Modbus communication	
	SN			
Safety	P24S	24V supply for safety	24VDC power supply for connecting safety contacts	
	GS1	Safe input 1	Safety input terminal 1	
	GS2	Safe input 2	Safety input terminal 2	
	CMS	Safety inputs common	Common for the safety input terminals	

Side by side mounting

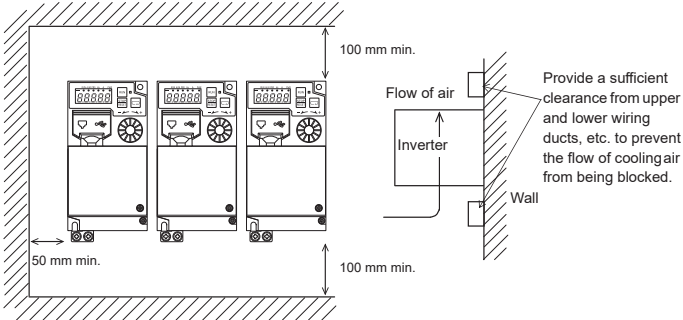

Drive heat loss

Single-phase 200 V class

Model 3G3MX2-EV2		AB001	AB002	AB004	AB007	AB015	AB022
Drive capacity kVA	200V VT	0.4	0.6	1.2	2.0	3.3	4.1
	200V CT	0.2	0.5	1.0	1.7	2.7	3.8
	240V VT	0.4	0.7	1.4	2.4	3.9	4.9
	240V CT	0.3	0.6	1.2	2.0	3.3	4.5
Rated current (A) VT		1.2	1.9	3.4	6.0	9.6	12.0
Rated current (A) CT		1.0	1.6	3.0	5.0	8.0	11.0
Total heat loss		12	22	30	48	79	104
Efficiency at rated load		89.5	90	93	94	95	95.5
Cooling Method		Self cooling				Forced-air-cooling	

Three-phase 200 V class

Model 3G3MX2-EV2		A2001	A2002	A2004	A2007	A2015	A2022	A2037	A2055	A2075	A2110	A2150
Drive capacity kVA	200 VT	0.4	0.6	1.2	2.0	3.3	4.1	6.7	10.3	13.8	19.3	23.9
	200 CT	0.2	0.5	1.0	1.7	2.7	3.8	6.0	8.6	11.4	16.2	20.7
	240 VT	0.4	0.7	1.4	2.4	3.9	4.9	8.1	12.4	16.6	23.2	28.6
	240 CT	0.3	0.6	1.2	2.0	3.3	4.5	7.2	10.3	13.7	19.5	24.9
Rated current (A) VT		1.2	1.9	3.4	6.0	9.6	12.0	19.6	30.0	40.0	56.0	69.0
Rated current (A) CT		1.0	1.6	3.0	5.0	8.0	11.0	17.5	25.0	33.0	47.0	60.0
Total heat loss		12	22	30	48	79	104	154	229	313	458	625
Efficiency at rated load		89.5	90	93	94	95	95.5	96	96	96	96	96
Cooling Method		Self cooling					Forced-air-cooling					

Three-phase 400 V class

Model 3G3MX2-EV2		A4004	A4007	A4015	A4022	A4030	A4040	A4055	A4075	A4110	A4150
Drive capacity kVA	380V VT	1.3	2.6	3.5	4.5	5.7	7.3	11.5	15.1	20.4	25.0
	380V CT	1.1	2.2	3.1	3.6	4.7	6.0	9.7	11.8	15.7	20.4
	480V VT	1.7	3.4	4.4	5.7	7.3	9.2	14.5	19.1	25.7	31.5
	480V CT	1.4	2.8	3.9	4.5	5.9	7.6	12.3	14.9	19.9	25.7
Rated current (A) VT		2.1	4.1	5.4	6.9	8.8	11.1	17.5	23.0	31.0	38.0
Rated current (A) CT		1.8	3.4	4.8	5.5	7.2	9.2	14.8	18.0	24.0	31.0
Total heat loss		35	56	96	116	125	167	229	296	411	528
Efficiency at rated load		92	93	94	95	96	96	96	96.2	96.4	96.6
Cooling Method		Self cooling	Forced-air-cooling								

Input AC Reactor

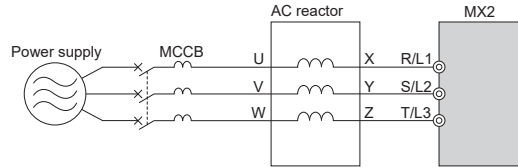

1 phase 200 V class				3 phase 200 V class				400 V class			
Max. applicable motor output kW	Reference	Current value A	mH	Max. applicable motor output kW	Reference	Current value A	mH	Max. applicable motor output kW	Reference	Current value A	MH
0.4	AX-RAI02000070-DE	7.0	2.0	1.5	AX-RAI02800080-DE	8.0	2.8	1.5	AX-RAI07700050-DE	5.0	7.7
0.75	AX-RAI01700140-DE	14.0	1.7	3.7	AX-RAI00880200-DE	20.0	0.88	4.0	AX-RAI03500100-DE	10.0	3.5
1.5	AX-RAI01200200-DE	20.0	1.2	7.5	AX-RAI00350335-DE	33.5	0.35	7.5	AX-RAI01300170-DE	17.0	1.3
2.2	AX-RAI00630240-DE	24.0	0.63	15	AX-RAI00180670-DE	67.0	0.18	15	AX-RAI00740335-DE	33.5	0.74

DC Reactor

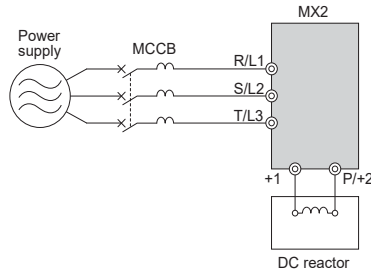

200 V class				400 V class			
Max. applicable motor output kW	Reference	Current value A	Inductance mH	Max. applicable motor output kW	Reference	Current value A	Inductance mH
0.2	AX-RC21400016-DE	1.6	21.4	0.4	AX-RC43000020-DE	2.0	43.0
0.4	AX-RC10700032-DE	3.2	10.7	0.7	AX-RC27000030-DE	3.0	27.0
0.7	AX-RC06750061-DE	6.1	6.75	1.5	AX-RC14000047-DE	4.7	14.0
1.5	AX-RC03510093-DE	9.3	3.51	2.2	AX-RC10100069-DE	6.9	10.1
2.2	AX-RC02510138-DE	13.8	2.51	3.0 to 4.0	AX-RC06400116-DE	11.6	6.40
3.7	AX-RC01600223-DE	22.3	1.60	5.5	AX-RC04410167-DE	16.7	4.41
5.5	AX-RC01110309-DE	30.9	1.11	7.5	AX-RC03350219-DE	21.9	3.35
7.5	AX-RC00840437-DE	43.7	0.84	11.0	AX-RC02330307-DE	30.7	2.33
11.0	AX-RC00590614-DE	61.4	0.59	15.0	AX-RC01750430-DE	43.0	1.75
15.0	AX-RC00440859-DE	85.9	0.44		-		

Output AC Reactor

200 V class				400 V class			
Max. applicable motor output kW	Reference	Current value A	Inductance mH	Max. applicable motor output kW	Reference	Current value A	Inductance mH
0.4	AX-RAO11500026-DE	2.6	11.50	1.5	AX-RAO16300038-DE	3.8	16.30
0.75	AX-RAO07600042-DE	4.2	7.60				
1.5	AX-RAO04100075-DE	7.5	4.10				
2.2	AX-RAO03000105-DE	10.5	3.00	2.2	AX-RAO11800053-DE	5.3	11.80
3.7	AX-RAO01830160-DE	16.0	1.83	4.0	AX-RAO07300080-DE	8.0	7.30
5.5	AX-RAO01150220-DE	22.0	1.15	5.5	AX-RAO04600110-DE	11.0	4.60
7.5	AX-RAO00950320-DE	32.0	0.95	7.5	AX-RAO03600160-DE	16.0	3.60
11	AX-RAO00630430-DE	43.0	0.63	11	AX-RAO02500220-DE	22.0	2.50
15	AX-RAO00490640-DE	64.0	0.49	15	AX-RAO02000320-DE	32.0	2.00

Ordering information

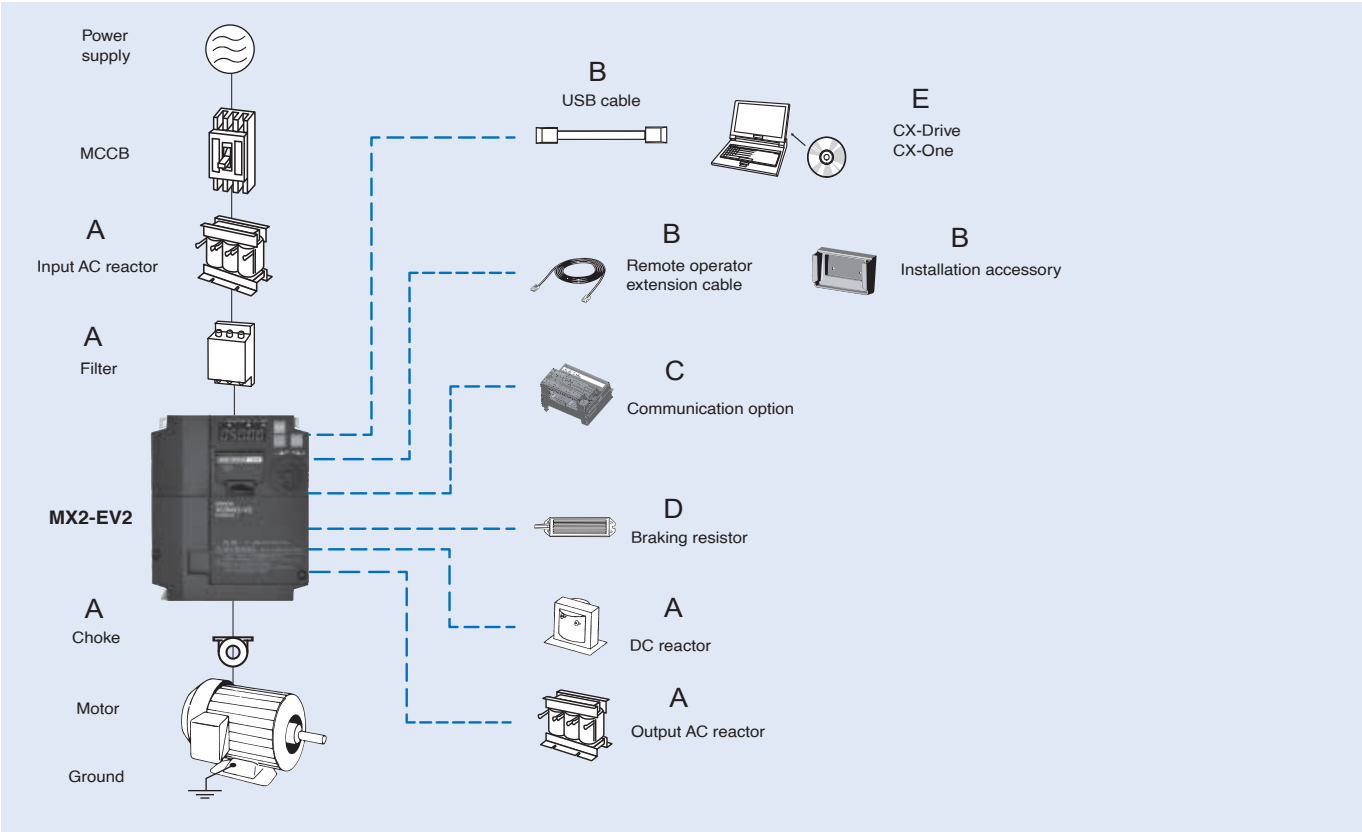

Voltage class	Specifications				Model
	Constant torque		Variable torque		Standard
	Max motor kW	Rated current A	Max motor kW	Rated current A	
Single-phase 200 V	0.1	1.0	0.2	1.2	3G3MX2-AB001-EV2
	0.2	1.6	0.4	1.9	3G3MX2-AB002-EV2
	0.4	3.0	0.55	3.5	3G3MX2-AB004-EV2
	0.75	5.0	1.1	6.0	3G3MX2-AB007-EV2
	1.5	8.0	2.2	9.6	3G3MX2-AB015-EV2
	2.2	11.0	3.0	12.0	3G3MX2-AB022-EV2
Three-phase 200 V	0.1	1.0	0.2	1.2	3G3MX2-A2001-EV2
	0.2	1.6	0.4	1.9	3G3MX2-A2004-EV2
	0.4	3.0	0.55	3.5	3G3MX2-A2004-EV2
	0.75	5.0	1.1	6.0	3G3MX2-A2007-EV2
	1.5	8.0	2.2	9.6	3G3MX2-A2015-EV2
	2.2	11.0	3.0	12.0	3G3MX2-A2022-EV2
	3.7	17.5	5.5	19.6	3G3MX2-A2037-EV2
	5.5	25.0	7.5	30.0	3G3MX2-A2055-EV2
	7.5	33.0	11	40.0	3G3MX2-A2075-EV2
11	47.0	15	56.0	3G3MX2-A2110-EV2	
15	60.0	18.5	69.0	3G3MX2-A2150-EV2	
Three-phase 400 V	0.4	1.8	0.75	2.1	3G3MX2-A4004-EV2
	0.75	3.4	1.5	4.1	3G3MX2-A4007-EV2
	1.5	4.8	2.2	5.4	3G3MX2-A4015-EV2
	2.2	5.5	3.0	6.9	3G3MX2-A4022-EV2
	3.0	7.2	4.0	8.8	3G3MX2-A4030-EV2
	4.0	9.2	5.5	11.1	3G3MX2-A4040-EV2
	5.5	14.8	7.5	17.5	3G3MX2-A4055-EV2
	7.5	18.0	11	23.0	3G3MX2-A4075-EV2
	11	24.0	15	31.0	3G3MX2-A4110-EV2
15	31.0	18.5	38.0	3G3MX2-A4150-EV2	

A Linefilters

Drive		Standard		Low leakage	
Voltage	Model 3G3MX2-EV2	Reference	Current (A)	Reference	Current (A)
1Phase 200 VAC	AB001 / AB002 / AB004	AX-FIC1010-SE	7.3	AX-FIC1010-SE-LL	7.3
	AB007	AX-FIC1020-SE	13.8	AX-FIC1020-SE-LL	13.8
	AB015	AX-FIM1024-SE ^{*1}	27	AX-FIM1024-SE-LL ^{*1}	27
		AX-FIC1030-SE ^{*2}	24	AX-FIC1030-SE-LL ^{*2}	24
		AX-FIC1030-SE ^{*2}	24	AX-FIC1030-SE-LL ^{*2}	24
3Phase 200 VAC	A2001 / A2002 / A2004	AX-FIC4005-SE ^{*2}	4.3	AX-FIC4005-SE-LL ^{*2}	4.3
	A2007	AX-FIC4010-SE ^{*2}	9.4	AX-FIC4010-SE-LL ^{*2}	9.4
	A2015 / A2022	AX-FIC4015-SE ^{*2}	14	AX-FIC4015-SE-LL ^{*2}	14
	A2037	AX-FIC4030-SE ^{*2}	24	AX-FIC4030-SE-LL ^{*2}	24
	A2055 / A2075	AX-FIC4050-SE ^{*2}	44	AX-FIC4050-SE-LL ^{*2}	44
	A2075 / A2110 / A2150	AX-FIC4080-SE ^{*2}	81	AX-FIC4080-SE-LL ^{*2}	81
3Phase 400 VAC	A4004 / A4007	AX-FIC4005-SE	4.3	AX-FIC4005-SE-LL	4.3
	A4015 / A4022 / A4030	AX-FIC4010-SE	9.4	AX-FIC4010-SE-LL	9.4
	A4040	AX-FIC4015-SE	14	AX-FIC4015-SE-LL	14
	A4055 / A4075	AX-FIC4030-SE	24	AX-FIC4030-SE-LL	24
	A4110 / A4150	AX-FIC4050-SE	44	AX-FIC4050-SE-LL	44

*1. No UL approved

*2. No footprint

A Input AC reactors

Drive		AC Reactor
Voltage	Model 3G3MX2-EV2@	Reference
1-Phase 200 VAC	AB002 / AB004	AX-RAI02000070-DE
	AB007	AX-RAI01700140-DE
	AB015	AX-RAI01200200-DE
	AB022	AX-RAI00630240-DE
3-Phase 200 VAC	A2002 / A2004 / A2007	AX-RAI02800080-DE
	A2015 / A2022 / A2037	AX-RAI00880200-DE
	A2055 / A2075	AX-RAI00350335-DE
	A2110 / A2150	AX-RAI00180670-DE
3-Phase 400 VAC	A4004 / A4007 / A4015	AX-RAI07700050-DE
	A4022 / A4030 / A4040	AX-RAI03500100-DE
	A4055 / A4075	AX-RAI01300170-DE
	A4110 / A4150	AX-RAI00740335-DE

A DC reactors

200 V 1-phase		200 V 3-phase		400 V 3-phase	
3G3MX2-EV2	DC Reactor	3G3MX2-EV2	DC Reactor	3G3MX2-EV2	DC Reactor
AB001	AX-RC10700032-DE	A2001	AX-RC21400016-DE	A4004	AX-RC43000020-DE
AB002		A2002		A4007	
AB004	AX-RC06750061-DE	A2004	AX-RC10700032-DE	A4015	AX-RC14000047-DE
AB007	AX-RC03510093-DE	A2007	AX-RC06750061-DE	A4022	AX-RC10100069-DE
AB015	AX-RC02510138-DE	A2015	AX-RC03510093-DE	A4030 / A4040	AX-RC06400116-DE
AB022	AX-RC01600223-DE	A2022	AX-RC02510138-DE	A4055	AX-RC04410167-DE
		A2037	AX-RC01600223-DE	A4075	AX-RC03350219-DE
		A2055	AX-RC01110309-DE	A4110	AX-RC02330307-DE
		A2075	AX-RC00840437-DE	A4150	AX-RC01750430-DE
		A2110	AX-RC00590614-DE		
		A2150	AX-RC00440859-DE		

A Chokes

Model	Diameter	Description
AX-FER2102-PE	21	For 2.2 KW motors or below
AX-FER2815-PE	28	For 15 KW motors or below
AX-FER5045-PE	50	For 45 KW motors or below

A Output AC reactor

Drive		AC Reactor
Voltage	Model 3G3MX2-EV2@	Reference
200 VAC	AB001 / AB002 / AB004 A2001 / A2002 / A2004	AX-RAO11500026-DE
	AB007 / A2007	AX-RAO07600042-DE
	AB015 / A2015	AX-RAO04100075-DE
	AB022 / A2022	AX-RAO03000105-DE
	A2037	AX-RAO01830160-DE
	A2055	AX-RAO01150220-DE
	A2075	AX-RAO00950320-DE
	A2110	AX-RAO00630430-DE
400 VAC	A2150	AX-RAO00490640-DE
	A4004 / A4007 / A4015	AX-RAO16300038-DE
	A4022	AX-RAO11800053-DE
	A4030 / A4040	AX-RAO07300080-DE
	A4055	AX-RAO04600110-DE
	A4075	AX-RAO03600160-DE
	A4110	AX-RAO02500220-DE
A4150	AX-RAO02000320-DE	

B Accessories

Types	Model	Description	Functions
Digital operator	3G3AX-CAJOP300-EE	Remote operator cable	3 meters cable for connecting remote operator
	3G3AX-OP01	LED remote operator	LED remote operator, cable length max. 3m
	4X-KITMINI	Mounting kit for LED operator	Mounting kit for LED operator on panel

C Communication option boards

Types	Model	Description	Functions
Communication options	3G3AX-MX2-ECT	EtherCAT option board	Used for running or stopping the drive, setting or referencing parameters, and monitoring output frequency, output current, or similar items through communications with the host controller.

D Braking unit, braking resistor unit

Voltage	Drive			Braking resistor unit						
	Max. motor kW	Drive 3G3MX2@-EV2		Connectable min. resistance Ω	Drive mounted type (3% ED, 10 sec max)		Drive mounted type (10% ED, 10 sec max)			
		1-phase	3-phase		Type AX-	Resist Ω	Braking torque %	Type AX-	Resist Ω	Braking torque %
200 V (Single-/Three-phase)	0.12	B001	2001	100	REM00K1400-IE	400	200	REM00K1400-IE	400	200
	0.25	B002	2002				180			180
	0.55	B004	2004	50	REM00K1200-IE	200	180	REM00K1200-IE	200	180
	1.1	B007	2007				100	REM00K2070-IE	70	200
	1.5	B015	2015	35	REM00K2070-IE	70	140	REM00K4075-IE	75	130
	2.2	B022	2022				90	REM00K4035-IE	35	180
	4.0	-	2040		REM00K4075-IE	75	50	REM00K6035-IE	35	100
	5.5		2055	20	REM00K4035-IE	35	75	REM00K9020-IE	20	150
	7.5		2075	17			55	REM01K9017-IE	17	110
	11		2110		REM00K6035-IE	35	40	REM02K1017-IE	17	75
400 V (Three-phase)	0.55		2150	10	REM00K9017-IE	17	55	REM03K5010-IE	10	95
	1.1		4004	180	REM00K1400-IE	400	200	REM00K1400-IE	400	200
	1.5		4007				200			200
	2.2		4015	100	REM00K1200-IE	200	190	REM00K2200-IE	200	190
	3.0		4022			REM00K2200-IE	200	130	REM00K5120-IE	120
	4.0		4030		REM00K2120-IE	120	160			160
	5.5		4040	70			120	REM00K6100-IE	100	140
	7.5		4055			REM00K4075-IE	75	140	REM00K9070-IE	70
	11		4075				100	REM01K9070-IE	70	110
	15		4110		REM00K6100-IE	100	50	REM02K1070-IE	70	75
		4150	35	REM00K9070-IE	70	55	REM03K5035-IE	35	110	

E Computer software

Types	Model	Description	Installation
Software	CX-Drive	Computer software	Configuration and monitoring software tool
	CX-One	Computer software	Configuration and monitoring software tool

ALL DIMENSIONS SHOWN ARE IN MILLIMETERS.
 To convert millimeters into inches, multiply by 0.03937. To convert grams into ounces, multiply by 0.03527.